



E. Paul Robsham, Jr.  
Scout Reservation  
**Camp Resolute**  
*We Do More!*

## 2009 Leader's Guide

# CAMP RESOLUTE

*We Do  
More!*

*Naturally Adventurous!*



A Knox Trail Council Camp

Boy Scouts of America

[www.campresolute.org](http://www.campresolute.org)



# Dedication

---

This guidebook is dedicated to

## **Edward “Buster” Messom**

A volunteer who gave unselfishly  
of his time and talents to  
Resolute and Webelos Camp Program.

# From the Camp Management Team...

---

January 2009

Dear Scouter,

Welcome home to Camp Resolute! If this is your first year here at Camp Resolute, we're confident that you'll find plenty of great activities for you and your Scouts to enjoy. If you're returning to us for another great season, we hope you'll create some great new memories that will last for many years. Either way, you're sure to have a great time, since this will be one of the best seasons that Camp Resolute has ever seen!

So why is this season going to be so great? There are many reasons why, and first and foremost is our program. Our motto "We Do More" keeps us striving to make our program better. Our afternoon programs have been enhanced, so that you can find great things to do every afternoon. Specialty Week has added two new programs in Equestrian Week and Angler Week; both of which are guaranteed to be a great time. We're continuing some of our great events that we recently started, such as last year's big hit MLB Night. Read through this guide to find out all of the great programs that we have to offer!

Last year's staff was the most energetic and enthusiastic staff that we've seen in a long time. With many of them returning for another great summer, expect your Scouts to leave on Friday eagerly awaiting 2010. We take pride in our staff, and the 2009 crew will prove to be another fantastic team. We expect a lot of ourselves this summer. Feel free to come to us with any questions or concerns you have, so that we can continue to make Resolute a better place. We hope that you and your Scouts have a great summer!

Yours in Scouting,

Rick Riopelle  
Camp Director

Andrew Taft  
Program Director

Carol Chesna  
Business Director

# Table of Contents

<b>Registration, Fees &amp; Planning</b>	<b>8 - 10</b>	Leader's Coffee and Tea	21
Camp Fees	8	Keeping the Whole Camp Clean	21
Settling Your Account by May 1st	8	Off-Limits Areas	21
Camperships	8	Retreat Ceremonies	21
Refunds	8	Quartermaster Store	22
Adult Leadership	8	Conservation	22
Provisional Troop 244	9	Good Turns	22
Unit Leader's Pre-Camp Planning Mtg.	9	Dining Hall	22
Troop's Own Camp Planning Meeting	9	Guest and Visitor Meals	22
Troop Photographs	10	Trading Post	22
Campsite Changes	10	The Buddy System	23
Chicken Bar-B-Que	10	Religious Services	23
Merit Badge Blue Cards	10	Know Your Parents	23
Suggested Equipment for Units	10	Merit Badge Partials	23
<b>Your Unit's Arrival &amp; Departure</b>	<b>11 - 12</b>	Rainy Day Programs	23
Unit Leader Arrival	11	Adult Opportunities in Camp	23
Camper Arrival	11	Scout Leader Cook-Off	24
Lunch	11	Unit Accounts	24
Parking	11	Advancement Awards	24
Once Campers Arrive	11	Order of Taunkacoo	24
Hold A Troop Meeting	11	Discipline in Areas	24
General Equipment	12	New Program Idea?	24
Departure from Camp	12	Leader's Lounge	24
Unit Leader Check-Out	12	Flag Ceremonies in your Campsite	25
		Planning the Troop Program	25
<b>Health, Safety &amp; Sanitation</b>	<b>13 - 19</b>	<b>Program Areas</b>	<b>26 - 27</b>
Medical Forms	13	<b>Afternoon Activities</b>	<b>28</b>
Illness and Accidents	13	<b>Older Scout Opportunities</b>	<b>29 - 30</b>
Latrines	13	C.O.P.E.	29
Personal Hygiene	13	Mountain Man	29
Camp Safety	14	BSA Lifeguard	30
Banned Items	14	<b>Resolute Recruits</b>	<b>31</b>
Smoking	15	<b>Evening Programs</b>	<b>32</b>
Taps	15	Aquatics Meet	32
Youth Protection Policy	15	Vespers & Troop Night	32
Emergencies	15	Order of the Arrow Day	32
Camp Office	16	Resolute Challenge	32
Campsite Daily Duties	17	Apache Relay	32
Campsite Inspection	17	Closing Campfire	32
Site Safety	17	<b>Special Programs</b>	<b>33</b>
Camp Roads	17	Polar Bear Swim	33
Campers' Bill of Rights	18	Friendship Campfires	33
Camper Security Policy	18	Little Pond Triathlon	33
Intrusion of Unauthorized Persons	19	Intertroop & Staff Challenges	33
Camper Release Policy	19	Scout Leader Cook-Off	33
Verification of "No Show" Policy	19	<b>Advancement &amp; Merit Badges</b>	<b>34 - 37</b>
Coming and Going During the Week	19	Advancement Steps	34
<b>Program Related Information</b>	<b>20 - 24</b>	Skills	34
Uniforms	20	Resolute Merit Badge Program	34
Telephone Use	20	Independent Study Merit Badges	35
Mail	20	Pre-Camp Merit Badge Requirements	35
Radio Communication	20	<b>Schedules &amp; Unit Leader Forms</b>	<b>38 - 70</b>
Camp Pranks	20		
Daily Morning Meetings	20		
Senior Patrol Leaders' Council	20		
Senior Patrol Leaders' Role at Camp	21		

# Camp Resolute History

---

By: Ralph Whitman, First Scout Executive

In the first three years of the Council, it had grown from two towns, Framingham and Marlboro, to nineteen towns. We had had makeshift camps the first three summers, so the Executive Board decided it was time to search for a permanent campsite. Two committees were appointed, the President, Hon. Edward F. Brown and Ralph Whitman to search the northern area and John M. Merian and Joseph Mundy of Framingham to search the southern area.

Ed Brown and I were lucky to look over what is now Camp Virginia on West Pond, Bolton, but we told the owner, Mrs. Hamilton; "This is not large enough for our needs." She responded, "My sister, Mrs. Townsend owns 150 acres across the way on Little Pond." We made an appointment to see it, and it was a case of love at first sight. On the following Sunday afternoon, the Executive Board met on the plateau in the rain, looked out on the pond and voted unanimously to purchase it.

If my memory serves me right, the price was \$60 per acre, or \$9,000 for the 150 acres. In the present market one shoreline lot would be worth more than that.

This was about April 1<sup>st</sup>, and it gave us a challenge to get a building ready for the camp opening on July 1<sup>st</sup>. I sent to National Headquarters, then in New York City, and they sent me a plan for a 40-foot x 48-foot dining hall with a big stone fireplace on one end. It so happened that, while in high school, I had studied architecture at the Marlboro Public Library, so I automatically became the architect of the hall.

Two years before, while I was at church in Northboro with the Scouts, Hugh Smith came to me at the close of the service and offered to build a stone fireplace in honor of his school mate in England, Lord Baden Powell, the founder of Scouting. I asked him if his offer was still good and he said, "Yes, absolutely." Within a few days, he was camping out at Little Pond, and the Scouts (mostly Troop 4, of Marlboro) aided by an army mule and a stone drag were bringing from our own walls the 50 tons of stone needed. As the fireplace

progressed, the men of this Council, including President Brown, Russell Frye, President of the Marlboro Peoples National Bank, Henry Warren of Ashland, inventor of the Telechron clock, and many others put in the rest of the foundation.

Gar Bason, District Governor of the Kiwanis Club and our first Council Commissioner laid the floor. He then got the Framingham Kiwanis Club to send up Jern Howards a carpenter to frame the building and tie it into the fireplace. This done, the leaders, Scouts, and I boarded it in and roofed it. Most of the shutters came from the Mount Waith Camp meeting grounds in Framingham, the gift of Rev. Henry Bray.

On the day that we were to top the big fireplace, it was 100 degrees in the shade and speaking both for Mr. Smith and myself, I suggested that we postpone the topper. "Nothing doing," was Mr. Smith's reply. "This is the perfect day to top the chimney." So it was completed, and at the Dedication it worked beautifully.

Waldo B. Fay, a member of the Executive Board from Southboro, called and said they were rebuilding their kitchen at Fay School, and offered us a large hotel range and a huge refrigerator. These we installed in the basement kitchen, the food went up in a dumb waiter or small elevator.

The Charlestown Navy Yard sent out notices of the sale of surplus navy tables and benches. We bought the whole lot and sold one-third to the Greater Lynn Council, and one-third to the Greater Worcester Council (now Mohegan), and our third cost us very little.

We were fortunate in our water supply, because we could drive a well point at most any spot and come up with nice spring water.

For the latrines, the gritty section of sandy gravel made wonderful cement.

Scoutmaster O'Connell, of Marlboro, a lineman for the Marlboro Electric Company got his pals to help him run the line from Route 85 to the dining hall. The only cost being for the pole, wire, and fittings.

The Council did not have to pay one cent for labor for the whole camp project except the \$50 a week I was receiving as Scout Executive.

# Camp Resolute History

---

With the water front layout completed and the boats coming from Maine, we were ready to open camp. Kiwanian, Arthur Young, head of the Framingham Coal Co. (in the quiet season) sent up men, horses, plows, and harrows and they laid out and seeded an athletic field.

The Camp Committee decided to have the Scouts compete in naming the Camp, and to give a free week at Camp to the winner. The yacht "Resolute" had just won America's Cup, and Kenneth Post of Troop 2, Marlboro, entered that name. "Resolute" it was and Post had his free week, and "Resolute" opened its first session, a successful one.

Running the whole width of the property is an abandoned embankment, which was supposed to carry the Hudson and Lancaster Steam Railroad.

In 1924, Normand Lindsay, Scoutmaster of Troop 1 of Marlboro, built a building for the washing of mess kits, with plenty of running hot water.

The Council purchased 6 1/3 acres of the Ordway land along the road heading into Camp, and had a public beach for the people of Bolton and Hudson, and on the other end (nearest camp) a large bunk house for the subdivision. This is now the site of the caretaker's cabin.

When it was rumored that a dance hall was to be built on the end of the pond nearest to Route 85, the Executive Board voted to buy a 40 to 50 foot strip along that section.

Later, when the 20 or more acres of the Sargent property came on the market, the Council was not in a position to finance it, so the Scout Executive got a group of interested men to take one or more shares and formed the Little Pond Associates. This formed part of the southeast section of the shoreline, and contained about six cottages. One end was reforested by the Scouts with white pine seedlings, which are now large trees. This section was soon taken over by the Council. This purchase left only one small section of the shoreline owned by the Persons family.

At the Camp, a large wing was added to the dining hall, which contains a modern kitchen,

with a walk-in refrigerator, and underneath are garages.

Also, a very fine Administration Building has recently been completed. In 1969, the cottage across the pond was dedicated to one of our finest presidents, Andy Maish of Framingham. In 1971, the large dining hall was dedicated to Ralph H. Whitman, founder and builder of Camp Resolute.

A new open air pavilion, Buster's Place, was constructed in 2005 to house the handicraft program of the camp.

The summer of 2006 saw the debut of a brand new waterfront feature - AquaLaunch which proved very popular with campers and leaders alike.

The summer of 2008 saw the completion of Magee Village comprised of four staff cabins behind the Administration Building. The waterfront also received new boat docks and the dining hall floor was replaced.



# Registration, Fees & Planning

## Camp Fees

Troop camping	\$335
Brother discount	\$240
Provisional	\$335
Specialty Camp	\$335 and up
Any second week	\$239

**UPDATE!**  
**UPDATE!**  
**UPDATE!**

A \$30 early bird discount applies to those paying their balance before May 1. New Scouts and Webelos crossovers submitting their application with their fee always get the early bird discount. No discount on brother fee.

Provisional fee applies to first week present in the camp. If camper is in his second week in the camp he gets the discounted rate.

## Settling Your Account by May 1st

Unit leaders need to settle their account on or before May 1, 2009. Payments made before that date will receive a \$30 early bird discount per Scout. Please check your online troop account to be sure we have your latest camper count and all your fees have been submitted and recorded.

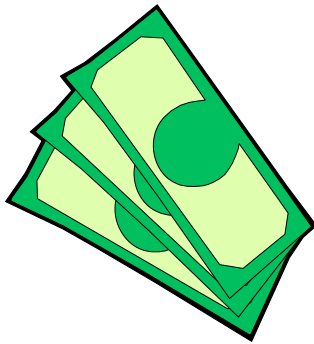

## Camperships

It is the policy of the Knox Trail Council that a Scout shall not miss the opportunity to attend summer camp because his family lacks the ability to pay the full camp fee. A limited number of partial camperships are available. The necessary form requiring certification form both the unit leader and parent/guardian can be found in the appendix.

Campership applications should be submitted by May 1. After that date availability of funds cannot be guaranteed.

## Refunds

All refunds of camp fees, exclusive of a \$50 per week nonrefundable cancellation fee, will be considered only if written communication is submitted to the council service center two weeks prior to the scheduled arrival date. If a camper does not show up for his reserved date, no fees will be refunded. No refunds can be granted for any reason after August 31, 2009.



## Adult Leadership

It is required that each troop provide full time supervision for Scouts by TWO or more adults. In accordance with the present National Boy Scouts of America policy regarding troop leadership, the primary troop leader must be at least 21 years of age and registered with the Boy Scouts of America. The second adult must be a registered Scouter 18 years old or older, or the parent of a participating unit member. The camp strongly encourages troops to enlist the help of at least one adult leader (over 21) who will stay with the troop for the entire week. Units may meet these requirements on a “rotating” basis. Rotating leaders must sign the log book at the Administration Building each time they enter or leave camp. Anyone planning to spend the night must have a current health form on file in the Health Lodge. All leaders, whether registered or not, must be screened with a CORI check. See Appendix for more info.

Units are allowed 2 adults free of charge. Additional leaders (minimum age of 18) are welcome in accordance with the following schedule:

1-16 Scouts	2 free leaders
17-24 Scouts	1 additional free leader
25-32 Scouts	2 additional free leaders
33-40 Scouts	3 additional free leaders

(same ratio continued for larger troops)

Leaders in excess of this ratio will pay \$75 per week for meal costs.

# Registration, Fees and Planning

## Provisional Troop 244

Our camp operated Provisional Troop is ready to host Scouts who want to stay at camp for any of several reasons:

- They would like to stay longer than their troop is camping
- They want to camp before your troop is scheduled to arrive
- They want to earn more merit badges

Camp Resolute operates a first class, fun filled provo troop. Be sure to promote it to your Scouts before coming and while at camp. Also ask the Provo Scoutmaster, a full-time staff member, to promote it to your Scouts before the end of your week.

**MULTI-WEEK DISCOUNT**  
If a Scout is in camp for his second or more week the fee is only \$239!

## Unit Leader's Pre-Camp Planning Meeting



Unit Leaders are *strongly* encouraged to attend the Pre-Camp Meeting that will be held at 7:30 p.m. the Wednesday evening prior to the unit's stay at camp. The adult who will have the primary responsibility for the troop in camp and the SPL for camp should attend. This meeting will be held at camp in the Dining Hall. The agenda will include Troop program planning, collection of medical

forms, a review of opening day procedures, "late breaking" news and answers to questions that you might have.

Please bring:

- A listing of all Scouts who will be attending camp with your troop
- This Leader's Guide
- Completed medical forms **including immunization record signed by a Doctor.**
- A list of special requirements such as dietary or religious food restrictions, Scouts with special needs, etc.
- 2010 Camp Resolute sign-up form and check for \$250

Prior to your check-in on Sunday your medical forms will be reviewed by the Camp Health Officer. The Unit Roster will be used to create buddy tags so they are ready at your check-in on Sunday. These two items are tremendous time savers and help to assure a smooth check-in for your Troop. Units that attend this meeting and have their paperwork in order will be processed on Sunday ahead of those who do not make the meeting or have incomplete paperwork.

### Week of Camp & Pre-Camp Meeting

Week 1 (July 5 - July 10)	July 1
Week 2 (July 12 - 17)	July 8
Week 3 (July 19 - 24)	July 15
Week 4 (July 26 - 31)	July 22
Week 5 (August 2 - 7)	July 29

## Your Troop's Own Camp Planning Meeting

We suggest you hold a meeting for your Scouts and parents in the spring to review camp advancement opportunities, personal equipment needs, arrival and departure information and other relevant issues. This might be your best opportunity to collect medical forms.

# Registration, Fees and Planning

## Troop Photographs



Troop photographs will be taken on Sunday before the evening meal. The schedule will be announced at your pre-camp meeting. Troop leaders should plan to turn in orders at the photo session. Each 8" x 10" color photo is \$10.00. Make checks payable to TOP Photography.

**UPDATE!**  
**UPDATE!**  
**UPDATE!**

## Merit Badge Sign-Up

Unit leaders will be responsible for signing their Scouts up for merit badge classes on our camp reservation and merit badge selection web site. Unit leaders will no longer need to complete and submit blue cards for their Scouts. At the end of each week the camp will print blue cards for each Scout. Log-in information for our website will be provided to the unit leader.

## Campsite Changes

If a Unit registers in numbers significantly above or below the capacity of the campsite that they have reserved, the camp leadership reserves the right to switch, or to ask a Unit to share, campsites. Every effort will be made to avoid this, but capacity may dictate the need. We thank you for your cooperation with this.

## Chicken Bar-B-Que

To aid us in the preparation of the Friday night feast, make sure that the parents know that they and other family members are welcome. The barbecue is a major component of the closing ceremonies and campfire - something the whole family will enjoy. There is no charge for the Scouts and adults attending camp. All other guests may purchase tickets at the Trading Post after checking their sons in on Sunday, or you may purchase guest tickets as a group at Sunday Night's Leaders' Meeting. COST: \$7.00 for Adults, \$5.00 for children 5 to 10 years old and under 4 years old are free.



## Suggested Equipment for Units

- Rope, assorted lengths
- American and Unit flags, poles and stands
- Merit Badge library
- Lanterns, mantles and fuel
- Thumbtacks
- Leaders' chairs
- Woods tools
- Plastic cover for bulletin board
- Extra dining fly
- Leader's stove and coffee kit
- Dependable alarm clock

NOTE: If unit tentage is used at camp, see Quartermaster for "NO FLAMES IN TENTS" sign.



# Your Unit's Arrival & Departure

## Unit Leader Arrival

Unit Leaders may arrive earlier than 1:00 p.m. for the purpose of setting up their campsite. Important: ALL vehicles MUST be out of Camp by 11:00 a.m. THE SPEED LIMIT IN CAMP IS 5 MILES PER HOUR! Please limit yourself to only one vehicle per troop. No vehicles will be allowed in Camp while Scouts are in Camp. Staff members are not available to assist Unit Leaders prior to 1:00 p.m. on Sunday.

## Camper Arrival

Sunday at  
1pm

Units will be allowed in camp at 1:00 p.m. Units should assemble in the parking lot. The Unit's Site Host will greet the unit at 1:00 p.m. in the parking lot. When everyone is together, the troop, accompanied by their Site Host may proceed to their site. Your site host will have prepared your site for your arrival, accounted for the existence and condition of necessary equipment, and will assist you through the rest of the check-in process according to a preassigned itinerary.



## Lunch

We advise campers and parents to eat before arriving at camp. For those who choose not to, our trading post offers snacks and refreshments.

## Parking...being fair to all

ALL vehicles must be parked in the Camp's parking lot. Vehicles are not allowed in the campsites. No vehicles other than Ranger and emergency vehicles will be allowed into the camp after 11:00 a.m. Sunday. Please observe all parking restrictions and parking personnel.

## Once Campers Arrive

Assemble your unit in the parking lot, then proceed to the site assigned to your troop accompanied by your Site Host. Your Site Host will confirm with you that all equipment in your site is in place and in good condition, then he/she will guide you through the check-in process, including medical rechecks, swim tests at the Waterfront, and Dining Hall Orientation.

*Make sure that you have all medical forms signed by parent and physician and include complete immunization history and insurance information!*

## Hold A Troop Meeting

Upon returning to your campsite you should hold a meeting with all your campers. Discuss items which you feel are of importance to your campers. The camp strongly recommends that you include these issues in your meeting (many of these items are covered in various sections of this guide, please review in advance.):

- Sunday's schedule
- Daily schedule and routine
- Campsite cleaning duties
- Health and safety rules
- Importance of a clean camp
- Use of the buddy system at all times
- Dining hall procedures, manners, and food serving
- Your personal expectations of your unit's members
- Emergency procedures
- Early morning, siesta, and lights out are "quiet time" in camp
- Encourage your Scouts to talk with the camp staff
- The availability of the provisional troop for Scouts who want to stay at camp after your troop's scheduled stay.

# Your Unit's Arrival & Departure

## General Equipment

Scouts are provided with a tent, platform, cot and mattress. Sites have a dining fly, picnic table, and a trash barrel. Each site has a latrine that is equipped with a latrine brush, broom, rake, hose, shovel, and Indian pump. Units are supplied with latrine disinfectant, rubber gloves and toilet paper from the quartermaster store. **Units are responsible for all equipment and campsite facilities.** Please take responsibility for these items. If they are missing upon your arrival, let your Site Host know so that he can arrange to have them made available for you.

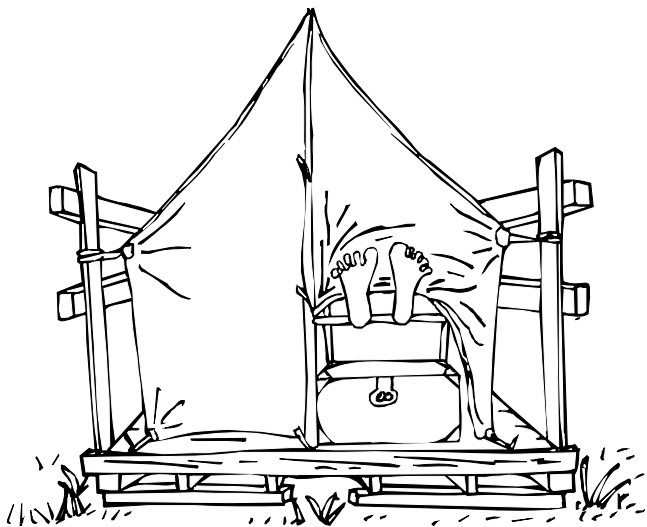

## Departure from Camp

Please make arrangements to clear your records in the Quartermaster Store by noon on Friday. Anything that your unit has borrowed from the Quartermaster Store and does not return will be charged to your unit. A final campsite inspection will be conducted by the Camp Commissioner prior to your departure. One vehicle per site will be allowed into camp during lunch on Friday to remove heavy camp gear from the sites.

Unit Leaders, Scouts and Parents are encouraged to attend closing activities that include the Chicken Barbecue, formal parade and retreat, and the closing campfire, which promises to be the highlight of the week. Folks leaving early will miss

unit awards and honor camper awards that will be passed out during the campfire. Unit leaders must make sure that all Scouts in your unit are being met by someone or have a way home.

## Unit Leader Check-Out

*You're responsible for your Scouts departure...*

Remember to inform your parents when to pickup their Scouts. It is important from both the unit leader's and camp's liability standpoint that unit leaders not leave camp until all Scouts have departed.

Units must check out with camp commissioner prior to leaving camp at the end of their week.



# Health, Safety & Sanitation

---

## Medical Forms

Every adult and Scout in camp **MUST** have a completely filled out medical form on file in the Health Lodge in order to stay at Camp Resolute. A physical exam must be completed within two years of attending camp for all participants under age 40. Participants over age 40 must have a physical exam every year. All medical forms must be retained by camp, so please make any copies you might need for other activities. If your physician provides you with a "signed" print-out, make sure that all information required for the camp form is provided...it may save you a trip back to his office! Make certain that both the parent's signature and physician's signature sections are filled out and the health insurance number is on the form. Every person, youth and adult, attending camp must also have a completed Certification of Immunization. Units with Christian Scientist members will need to provide a special medical form, located in the Forms Manual, pertaining to their faith's medical policies.

*Upon arrival in camp, the Health Officer will perform a medical recheck and collect all prescribed medications. (Bee sting kits and asthma inhalers may be kept at the site or with the Scout if necessary.) Medications must be in their original containers with a valid/current prescription label that bears the name of the drug, the dosage, the name of the prescribing physician, and the name of the individual for whom the drug was prescribed. This information must also be on the camp physical form. Containers with more than one drug, or improper labeling, will NOT be accepted. The health officer will then dispense medications as prescribed. **These requirements are mandated by law for camps. This applies to all youth AND adults.***

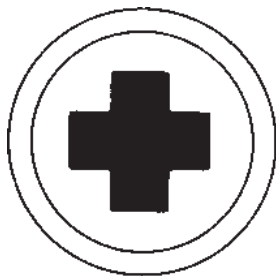

## Illness and Accidents

Report ALL accidents and illnesses to the Health Officer, who is responsible for the welfare of all and advises the Camp Director on these issues:

- At the first sign of illness or injury, bring the Scout to the Health Lodge.
- When serious accident or illness occurs, parents of the Scout will be notified immediately by the camp director or his designee.
- In case of emergency, Scouts will be taken to UMass Marlborough Medical Center. Unit leaders may be requested to drive the Scouts to the hospital.
- When a Scout is confined to bed in the Health Lodge, his parents will be notified and advised that if his condition persists for more than 24 hours, he should be returned home to recuperate.
- Night emergencies should always be referred to the Health Lodge.

## Latrines

Campsites have latrine and sink facilities centrally located. Troops are responsible for the daily cleaning of their latrine and sink. Latrine cleaning supplies and toilet paper will be available each morning after breakfast at the Quartermaster Store.

## Personal Hygiene

### *A Scout is Clean*

Unit leaders are asked to assure that your Scouts take frequent showers for personal hygiene and out of respect for others. For the same reasons, plus to teach by example, leaders should follow the same practice. A Scout is Clean!

### *Showers and Bathrooms - Scouts*

Scout showers are located on the left fork near Smoky Pines campsite and on the right fork near Sassamon campsite and should only be used by Scouts between reveille and taps. As previously stated, out of consideration, respect and for reasons of hygiene, Scouts should be encouraged to shower often.

# Health, Safety & Sanitation

---

## *Showers and Bathrooms - Adult*

Adult showers are opposite the Dining Hall. These showers are for adult leaders and camp staff only. Scouts are not permitted to use them. Adults are permitted to use the Scout showers (located on the left fork near Smoky Pines and on the right fork near Sassamon) after taps and before reveille.

We also recommend that campers and leaders wash their hands before each meal.

## **Camp Safety...**

### *Use common sense*

**Barefoot Walking** in camp is dangerous and therefore is not allowed! Scouts may only be without their shoes in the immediate waterfront area, camp showers and in their own tents.

**Running** is not allowed anywhere in camp...except on the sports field.

**Clotheslines** should be strung out of the way of foot traffic and should have something hung on them to indicate where they are. Tent outriggers are not to be used as clotheslines.

**Saws and axes** must be used only in the campsite's axe yard. They must be stored in either the axe yard or the equipment tent.

**Buddy system** must be used by all campers wherever they go in camp. This is a basic safety precaution even for experienced campers.

**Liquid Fuel** stoves or lanterns can only be used after permission is obtained from the Camp Director. National B.S.A. regulations state that all bulk liquid fuel containers must be stored by the Ranger. A shed has been made available for that purpose, near the main storage sheds. Propane may be used when underwriter approved cylinders are used. **DO NOT** place empty cylinders in the trash; take them home. **Remember: No flames in tents!**

**No flames in tents...**the only safe way to illuminate the inside of a tent is by flashlight. No burning flames or enclosed lanterns in tents.

**Sheath knives** with fixed blades 3" or longer, except for cooking knives that belong in cooking equipment, are prohibited in camp.

**Vehicles** will not be permitted beyond the camp parking lot. (With the exception of the camp truck and necessary camp vehicles approved by the camp director.) The preservation of a sound camp environment is most important in this regard. Under no circumstances will passengers ride on the beds of trucks. In addition all riders must be wearing seatbelts.

**Firearms, ammunition, archery equipment and projectile equipment** are not allowed in camp.

## **Banned Items...**

### *For a secure camp*

The camp leadership reserves the right to confiscate any prohibited items from either campers or adults.

Prohibited items include:

- Alcoholic beverages
- Narcotics or prescription drugs in unmarked or improperly marked containers
- Fireworks
- Bow or arrows, guns or ammunition, or any other kind of weapon
- Sheath knives
- Double bit axes
- Aerosol cans of ANY type
- Traps
- Televisions
- Any item determined by the camp leadership to be unsafe or used in an unsafe manner.

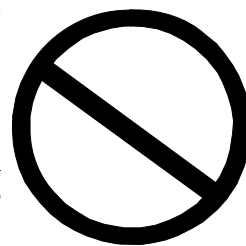

Unit leaders responsible for the supervision of their unit's youth are not to leave camp for the purpose of consuming alcoholic beverages nor return to camp after consuming alcoholic beverages.

# Health, Safety & Sanitation



## Smoking...not near Scouts

Cigarette smoking by Scouts is prohibited. Adults are required to use the designated smoking area located outside the camp gate. Smoking is not permitted in tents or any camp building. For those adults who smoke, please make sure you pick-up your butts.

## Taps

A Scout is courteous! Particular emphasis is placed on providing the opportunity of adequate sleep to every Scout each night. Unit Leaders should take special care to see that their camp site is a courteous one. Rowdiness and excessive noise after taps and before reveille are not acceptable behavior. Taps will be played at 10:00 pm nightly. At this time every Scout should be in his or her site. Any Scout caught outside their site without cause will be escorted back and the Scoutmaster will be awoken. After taps a leader is asked to escort Scouts to the health lodge.



## Youth Protection Policy

Camp Resolute has a responsibility to provide a safe and healthy environment for all who camp there. Camp leaders and staff must be alert to several types of abuse: physical, emotional, sexual, and neglect.

A BSA statement on this matter can be found at the council service center. Massachusetts state laws require that suspected incidents of child abuse must be reported to local law enforcement authorities. All suspicions should be brought to the attention of the Camp Director.

A close examination of this matter could identify some troops' "initiations" or hazing of new

campers as child abuse. Please be aware that hazing and initiations will not be permitted or tolerated. Troops or individuals engaging in such activities may be asked to leave camp without the advantage of a refund.

## Emergencies...

### *Stay Calm, Act Quickly but Safely*

Camp Resolute has a written Emergency Plan that will be reviewed in detail with each leader upon arrival. ANY EMERGENCY (lost Scout, fire, injury, etc.) MUST be reported to the Camp Administration Building IMMEDIATELY. In the event of a home emergency and a parent wishes to contact his/her Scout at camp, they may do so by contacting the camp office. All Massachusetts General Law for Children's Camps and the policies of the BSA are in force whether listed within this guide or not. You may reference the Guide to Safe Scouting for answers to many common questions.

## Fire

Send two runners immediately to the camp office with the following information:

1. The location of the fire;
2. The type of fire;
3. The severity of the fire;
4. And, what type of personal injury has occurred if any.

When fire call is sounded on the loudspeaker system, all Scouts, leaders, and visitors should report immediately to the Parade Field and await instructions from a staff member. A runner will be sent to the camp office with a head count as soon as it is safe to do so. DO NOT GATHER ON THE BLACKTOP IN FRONT OF THE DINING HALL AS EMERGENCY VEHICLES WILL BE TRAVELING THROUGH THAT LOCATION - STAY BACK FROM THE CAMPROAD AFTER REACHING THE PARADE FIELD UNLESS DIRECTED OTHERWISE BY A STAFF MEMBER.

# Health, Safety & Sanitation

---

## Lost Swimmer

The waterfront will be cleared immediately. Some adults may be requested to assist. At the sound of the LBD (Lost Bathers Drill) alarm, all Scouts, and unit leaders will report to their campsite where attendance will be taken by the unit leader. The unit leader will notify the camp office immediately, by runner or cell phone, of any missing personnel. The camp office will continue the LBD alarm until such time as the missing swimmer is located.

## Lost Camper

The unit leader will report any suspected lost camper to the camp office. The camp staff will then institute the appropriate search procedures.

## Extreme Heat

In the case of extreme heat, the camp administration will declare a heat alert and program activities will be adjusted accordingly. Unit leaders and Scouts are reminded to watch for symptoms of heat exhaustion and sunstroke. Watch especially for Scouts wearing inappropriate clothing and/or not taking adequate amounts of fluid.

## Lightning or Severe Storms

The waterfront will be cleared immediately. All watercraft will return to shore. Scouts will report to their campsites unless otherwise instructed by a staff member. Avoid open fields. Any other needed instructions will be issued by the camp office.

## Natural Disaster (Earthquake, Flood, Etc.)

In the event of a natural disaster all Scouts and adults should remain in the activity area they are in or go to the nearest campsite and await instructions from a staff member. If this is the area

that is affected then all personnel should move to the nearest safe area and await instructions.

## Wildlife

Campers, staff and visitors are cautioned to avoid contact with wildlife on the reservation at all times. Any injury caused by contact with wildlife must be reported to the Camp Health Officer as soon as possible. The Camp Health Officer will notify the Camp Office and the necessary local authorities as required.

## Major Accidents & Death

In the event of a major accident or death, the following staff personnel are to be notified by reporting the accident to the camp office by runner or cell phone: the Camp Director, the Program Director, and the Camp Health Officer.

## Child Abuse

The Camp Director must be notified of any incidence of child abuse. The report must include as much supporting information as possible. The report is to be kept confidential. Tell only those who have a need to know. Above all, protect the dignity and privacy of the victim.

## Chemical Spill

In the event of a chemical or hazardous waste spill, a person should be stationed to keep all campers or visitors away from the spill and the camp office must be notified by runners or cell phone.

## Camp Office/Emergency Number: (978) 779-2777

All serious medical emergencies will be treated at the UMass Marlborough Medical Center and parents/guardians will immediately be notified by the Camp Director or his representative of all details as they become available. In order to reduce

# Health, Safety & Sanitation

---

miscommunication of information, we do ask that leaders carrying cellular phones do not notify parents of accidents without authorization from the Camp Director or his designee. It is of great importance that each camp leader understands this and passes this information along, not only to the parents, but also to the Scouts as well.

## Campsite Daily Duties

It is recommended that units develop a duty roster that distributes the following tasks fairly among the entire unit:

**Fire Warden:** Makes sure that the rake, shovel and broom are hung properly. The site's fire pit should be neat and the firewood neatly stacked.

**Latrine:** Pick up trash, sweep floor, wash seats with brush and disinfectant, clean sink with disinfectant, rinse seats, sink and floor. Hang tools and hose when done.

**DO NOT POUR DISINFECTANT INTO THE LATRINE!**

**Waiters:** One waiter should be assigned per table for lunch & dinner daily. They must arrive 15 minutes before the meal.

**Campsite:** Stow unit gear and police site for litter.

**Tents:** Sweep all tent floors every day. Tent flaps should be rolled inward unless told otherwise at announcements. Personal gear should be stowed and trunks/suitcases locked. All gear not stowed (shoes, moccasins, etc.) should be aligned under the bunk. The bunks should be neatly made. Nothing should be hung on the tent frame. Tent lines should be taut. If a unit is using a tent for Troop equipment storage, all contents must be safely and neatly stored at all times.

## Campsite Inspections

Campsites are inspected daily by the Camp Commissioner. These inspections are primarily to assure site safety, sanitation and equipment care. You will be provided with a copy of the inspection form that you may wish to post on your bulletin board so that your campers will know what is expected of their unit. Please make sure that you have

assigned the necessary pre-inspection duties to your campers. Troops that use duty rosters have less trouble getting Scouts to do their fair share!

## Site Safety

Clotheslines should be strung outside the flow of foot traffic with the lowest point being 6 feet above the ground and visible. Woods tools must be used and stored in accordance with B.S.A. policy (axe yards, Totin' Chit, etc.). Make sure that your site is always prepared to deal with fire and know what to do. Always have a very visible First Aid kit where campers can reach it. Point out poison ivy to new campers. Teach them how to recognize it and how to treat it after contact.

## Camp Roads

The camp roads are not thoroughfares. All vehicles must remain parked in the main parking lot. No vehicles will be allowed in or around campsites or program areas. Please discuss special needs with the Camp Director.



*Please observe it for safety!*

# Health, Safety & Sanitation

---

## Campers' Bill of Rights

Dear Camper:

We want to make sure that your stay at camp is a pleasant one, and that you will carry home lots of great memories of your time at Resolute. Your troop's camp leader and resident staff will help you in every way they can to make this a great experience. But we need your help, too. Therefore, we have written up a few rules which you should follow while in camp.

1. The Scout Law is the law of the Camp. We mean it!
2. Wherever you go or whatever you do, go with a buddy...never go by yourself.
3. Leaders and staff are permitted to inspect your tent for cleanliness, but otherwise, your tent is yours and your friend's, and no other boy or adult has the right to stay with you in your tent. You should sleep only in your tent or in the Camp Health Lodge if you are sick.
4. Obey the instructions given by adult leaders and staff at all times, providing they are not in conflict with your own values and beliefs.
5. Be polite and courteous to other Scouts, leaders, and staff at all times. Say "Hi" when passing them on the trail.
6. Respect your body. Only Camp Medical Personnel are allowed to touch you when an illness or medical problem requires treatment.
7. When caught breaking a rule, you have the right to a fair hearing. But once your leaders have heard you, you are to accept disciplinary action without argument.

8. When participating in certain activities, always wear protective or safety equipment prescribed for that activity.
9. If you feel abused or misused by an adult, report this immediately. At the Administration Building, ask for "Rick."
10. Some other rules will be explained during your Sunday camp orientation and will be posted in your site.
11. The Scout Law is the law of the Camp. We mean it!

## Camper Security Policy

The security and safety of the youth in our charge is an extremely heavy responsibility. We must ensure that they are protected from unauthorized and unwarranted exposures, at the same time providing the freedom that is so essential to their maturing process. With this as our goal the following procedures apply:

1. At no time will youth be allowed alone beyond reasonable jurisdiction of staff members. When going from one area to another they shall travel in groups of no less than two.
2. Campers will be briefed to report all sightings of strangers to a staff member who will immediately report that information to the Camp Director.
3. All activities beyond parameters of the main camp will be furnished with means of communication to the Administration Building.
4. Campers will be released only to those individual(s) listed on the registration form or the Scoutmaster who will assure responsibility for same.

# Health, Safety & Sanitation

---

## Intrusion of Unauthorized Persons

Any Scout, leader, or staff member suspecting intrusion of an unauthorized person shall be instructed to report immediately to their leader or staff member of the area they are currently working. Leaders and staff shall be instructed to give a brief salutation if possible and direct them to sign-in at the administration office. If you are uneasy about approaching the individual or are given an inappropriate response, they will be instructed to notify the Camp Director of his/her designee immediately. The Camp Director shall assess situation and ask person to leave camp or notify authorities if appropriate.

## Camper Release Policy

Unit leaders are asked to inform the Camp Director in advance of any Scout who intends to leave camp during the week.

The safety of our campers is a shared responsibility. Please ensure the Camp Director is informed of any situation which could result in a Scout being released to someone other than an authorized adult. Child custody disputes are especially sensitive and should be relayed to the Camp Director.

Before a Scout can leave camp the adult escort must be identified by the unit leader. If the escort is not the Scout's parent, a letter from the parent authorizing release of the Scout is required. The adult taking a Scout out of camp must first sign-in at the Administration Building and be identified, a picture ID is required. The Scout and a unit leader should meet the visitor at the Administration Building.

When identity or authorization to pick up a Scout cannot be determined, the camper's family will be called to get authorization to release their son to the person at camp.

## Verification of "No Show Policy

In the event of a no-show at check-in, the following procedures shall be followed:

1. The unit leader should verify why the Scout did not arrive at camp and inform the camp director.
2. The Camp Director or Business Manager will call the Scout's family to verify the reason(s) of his absence from camp.
3. If you know a Scout will not be going to camp, please cancel his registration before check-in.

## Coming and Going During the Week...Sign In & Out

Adult leaders arriving or departing from camp during the week are required to sign in and sign out using the in/out book in the camp office. During regular office hours the book will be located inside the Camp Administration Building. Should an emergency situation occur, camp administration must know who is in camp at any time. Leaders leaving camp should make sure that proper coverage is provided during their absence.



# Program Related Information

---

## Uniforms

### *Looking the part*

The official B.S.A. field uniform is to be worn by all Scouts and adults during the evening meal, flag ceremonies, formal retreats and Troop photographs. This consists of a Scout shirt (long or short sleeved), trousers or shorts, BSA socks, a belt, a buckle, shoes, and proper insignias in proper locations. Neckerchiefs are optional.

## Telephone Use



son

Personal calls are discouraged. If a call is absolutely necessary, it should be kept short. Please use good judgement and make only vital calls. Ask the person in charge at the Administration Building before calling. Campers are strongly discouraged from making calls, as they can easily heighten homesickness. All outgoing calls should be collect or credit card calls. Scouts are required to have a unit leader present to make a call.

## Mail

Outgoing mail should be placed in the mailbox outside the Trading Post or in the Administration Building. Incoming mail arrives in the late afternoon and may be picked up by an adult leader at the Administration Building. Parents should send mail early in the week or even prior to the week to make sure it arrives in camp prior to the Scout's departure on Friday. Send mail to:

Your Scout's Name  
Troop # and Campsite  
Camp Resolute  
75 Hudson Road  
Bolton, MA 01740

## Radio Communication

Key camp staff use two-way radio communication to avoid disturbing the camp on the PA. If you happen to come across the Staff Radio code, please change your signal.

## Camp Pranks

It is the policy of the camp and council that camp pranks are not part of the Scouting program. In the past some troops have conducted and condoned pranks. Due to the inherent liability and risk to Scouts, staff, leaders, camp and personal property we ask that troops refrain from any and all pranks in camp. Once again, the main reason for this rule is the safety of everyone in camp. Camp Resolute is dedicated to the safety and security of every person within its premises.

## Daily Morning Meetings...

### *Keeping you informed, listening to your comments*

Each morning various members of Camp Leadership will hold an informal meeting with Unit Leaders. It is strongly recommended that at least one adult leader from each unit attend. The purpose of these meetings is to communicate important information and to address the immediate needs of our campers, leaders, and program. We ask that you bring reasonable items of concern to our attention at these meetings. We cannot solve issues of which we are unaware. Note; the SPL meeting's purpose will be to exchange information between the troop and the camp. Patrol leader's councils as well as direct meetings with the adult leadership will transfer this information back to the troop developing the troops boy leadership.

## Senior Patrol Leaders' Council

### *Stay informed!*

Each unit's SPL is a part of the camp SPL's Council, which meets daily immediately following lunch in the Training Room. At this meeting, camp-wide events are planned and other concerns will be addressed. SPLs should listen carefully to members of their Troop prior to attending the SPL's Council meeting in order to share his troop's experiences. He should pay particular attention to how merit badge classes are going. He should also lis-

# Program Related Information

---

ten for any additional activities his unit may want and report these as well. The SPL is the spokesperson for his unit's activities.

## Senior Patrol Leader's Role at Camp

The SPL, along with the Troop Guide, should be working with the new Scouts, helping them to determine what merit badges to take and what activities will help them have a good experience. The SPL should be a role model for all Scouts in his unit, and can advise the uninitiated on what to expect from camp. The SPL should be encouraging his patrols to be involved in and plan for the camp wide games, Aquatics Meet, Resolute Challenge and the Apache Relay Race. He should be available to coach the Scouts on their roles in each of these meets during the week so that they will all know their respective roles the day of the event.

The SPL should be involved in the planning for evening activities that is done during the SPL Council meeting each day. He should be sure that his Unit is represented at campfires with a song and/or a skit. The SPL should be the first to arrive at camp, along with the Scoutmaster. The SPL should be involved in the assigning of tents and be available to settle any disputes. He should be involved in the preparation of the duty roster for service and cleanup patrols, as well as for the roster of waiters for each meal.

The SPL is a vital link between the Units and Camp Staff. It is an important position within the unit. If the unit's SPL is not attending camp, care should be taken to elect a camp SPL who can fulfill the requirements of the position and take a leadership role during his week at camp. The SPL should be listened to by Scoutmasters and by the Camp Staff. By the same measure, the SPL should be the first Scout of his Unit to support the directions given by his Scoutmaster and/or Camp Staff.

## Leaders' Coffee and Tea

*We'll keep you going!*

The coffee is always hot and fresh for you and your adult leaders at the Dining Hall. Feel free to enjoy it anytime.

## Keeping the Whole Camp Clean

*We're known for a clean camp!*

A Scout is clean and it is expected that he keep his site and the whole camp neat and clean. Your troop is expected to do the Resolute Good Turn daily towards keeping the camp clean. Scoutmasters are urged to remind Scouts that they are responsible for keeping Camp Resolute the cleanliest camp around!

## Off-Limits Areas

The following areas are considered to be off limits to Scouts and Leaders during the following times:

- Bolton Beach at all times
- Staff sites including Magee Village at all times
- Aquatics areas when closed
- Project C.O.P.E. when closed
- Kitchen at all times - please contact Steward with needs
- Rifle range when closed

## Retreat Ceremonies

We will gather Sunday at 5:45pm and Monday-Thursday at 5:15pm for a formal flag lowering ceremony. The Camp Resolute Formal Parade and Retreat Ceremony will be held Sunday and at 7:15 p.m. on Friday at the Parade Field. We ask that all units arrive on time so that we can start promptly and arrive at the dining hall at 5:30 for dinner. On parade nights troops are encouraged to bring their troop and American flags. Please help us to make the parade something of which to be proud by encouraging your Scouts to participate in full Class A uniform.

**UPDATE !  
UPDATE !  
UPDATE !**

# Program Related Information

---

## Quartermaster Store

The Quartermaster Store is adjacent to the Trading Post. It will be open for 15 minutes after each meal. Toilet paper, latex gloves and latrine disinfectant are available here. **Warning: Be very careful when handling the disinfectant. If you spill it on your skin or clothes, flush with water and report to the Health Lodge. If you pour disinfectant down the latrine openings, it causes the latrine odor to become stronger.** A limited supply of tools for activities/training at your campsite and for service projects are available. Please sign these tools out and return them when finished, other units may have need of them. Please arrange to have all tools returned to the Quartermaster Store by Friday at noon. Tools that are not returned to the Quartermaster Store will be assumed lost and billed to the borrowing unit.

## Conservation

Please take care of the natural resources at Camp Resolute. Scouts are not to cut any living tree, shrub or bush. Be careful with fires in your area. Make sure that they are attended until out and that the ground has been cleared the proper distance around it. Do not clear away the pine needles other than around your fire ring. The needles help protect against the effects of erosion and should be left as they are. All sites should be “naturalized” each morning before the unit starts their schedule. These details will contribute to a favorable inspection score when the Commissioners check your site, so be sure to mention these procedures to Scouts in charge of the campsite each day.

## Good Turns

Each day units are asked to clean up various areas of camp. We ask that your Unit does its good turn right after breakfast. In addition, units are assigned an area of camp to police and maintain for the week. This assigned area should be policed in the morning. Both of these assignments will be reflected in the score of the daily inspection as applicable for each unit. A list of good turns will be

provided at camp.

## Dining Hall

*An uncommonly good eatery!*

**UPDATE!  
UPDATE!  
UPDATE!**

**Special Dietary Needs:** Our Cook and Dining Hall staff are able to accommodate many special dietary needs. If you are aware of any such needs in your unit, please ask the member’s parent(s) to contact the Cook one week prior to your unit’s arrival.

**In the Dining Hall:** Breakfast will be served buffet style. Lunch and dinner are served family style. Unit leaders are responsible for portion control and the good manners of their unit’s table(s). One adult leader is required at each table your unit occupies. Hats are not to be worn in the Dining Hall.

**Adults and older Scouts should set the example for younger members by participating in songs and activities after meals and urging their unit to join in.**

## Visitor and Guest Meals

Guests and visitors may eat with their unit. Arrangements should be made when the guests sign-in at the Administration Building with the Business Manager or Office Manager. Meal costs for visitors and guests are:

Breakfast	\$4.00
Lunch	\$5.00
Dinner	\$7.00

## Trading Post

Camp Resolute runs a well-maintained “general store” called a Trading Post. For sale are items from the exclusive Resolute Line of custom camp merchandise such as: T-shirts, hats, mugs, and patches. In addition we stock handicraft supplies, Scout supplies, merit badge pamphlets, toilet articles, stamps, post cards, candy, ice cold Coca-Cola, Hershey’s Ice Cream, refreshing slush, and other goodies. The amount of money your Scouts bring to camp is an individual matter between the Scout and his parents.

# Program Related Information

---

## The Buddy System

### *24 hours a day, seven days a week*

The buddy system is used at all times at Camp Resolute. No Scout should be outside of his campsite without another Scout as his buddy. Scoutmasters are asked to enforce this important rule.

## Religious Services

### *A Scout is reverent*

A Scout's duty to God is his first obligation and is a very important part of the Scouting program. A Scout's Own service will take place on Tuesday evening at 6:45pm. All campers and leaders are strongly encouraged to attend.

**UPDATE!**  
**UPDATE!**  
**UPDATE!**

## Know Your Parents

The camp assumes that all campers are in camp for the entire week. If a camper is to depart before the end of the week, please identify the adult removing the Scout from camp to the Camp Director as the Scout's parent and the one who has legal custody.

When Scouts are being picked-up at the end of the week, be certain that you know the person picking up the Scout as the one who is legally able to and will likely provide safe transportation home.

## Merit Badge Partial

If a boy has completed only part of the requirements for a merit badge, he may be given a "partial" stating which requirements have been met as well as those which have not been met. This "partial" will be valid until the Scout is 18 years old. Merit badge counselors may, however, reserve the right to review material with the Scout when they have completed the remainder of the requirements.

## Rainy Day Programs

It never rains at camp, but occasionally the dew gets very heavy. Be prepared in case a pro-

gram is washed out. You might try some of these:

- **A Rainy Day Hike:** in bathing suits if warm enough!
- **A Neckerchief Slide Contest:** using materials from nature.
- **Pioneering with Sticks and Twigs:** make small scale models of pioneering projects to be built on a clear day.
- **Fishing Derby:** worms and fish are both easier to catch on a rainy day.
- **Firebuilding Contest:** building a fire in the rain separates the "Tenderfeet" from the "Stars."
- **Songfest:** a great morale builder under a tarp when your campfire is rained out. Brew up some soup or hot chocolate.
- **Letter Writing:** who bothers to write letters when it's sunny out?!

## Adult Opportunities in Camp

No summer camp program could be successful without the assistance and cooperation of the Unit Leaders. Adult Volunteers are always welcome to help with any aspect of the program. If you or an adult in your unit has some unique skill or is willing to counsel a Merit Badge outside of the standard offerings, please contact the Program Director to make arrangements. There are also portions of the program that rely on Adult Volunteers in order to run. If you, or anyone you know, are willing to help out please contact the Program Director. Your assistance is a welcome and important part of the summer camp program.

**Training Courses:** We will be offering a variety of supplemental training opportunities for adult leaders during their stay at camp. These include Youth Protection, Climb on Safely, Trek Safely, Safety Afloat, and Safe Swim Defense. Additional courses may be available upon request or may be offered. This is a great opportunity to get some additional training without any additional nights out.

**C.O.P.E./Climbing:** Leaders are needed to assist with C.O.P.E./climbing sessions. Volunteers will

# Program Related Information

---

be trained by the area director in the necessary safety practices and activities.

**Mountain Man:** Leaders will help in supervising and ensuring safety during events. They will be trained in the necessary safety rules by the area staff.

**Hikes:** Leaders are needed to assist the staff with supervision.

**Waterfront Tower Duty:** We request that leaders sign up for at least one period of tower duty per week. It is required that an adult, over 21 years of age man the tower in order for waterfront activities to run. Sign-up sheets will be available at the Monday Scoutmaster's Meeting.

**Merit Badges:** We invite and encourage Scout Leaders to visit program areas and talk with the Merit Badge Counselors about the progress of their Scouts. Past experience has shown that Units with the best advancement records have had leaders who have visited all programs to make sure that their Scouts are where they are supposed to be.

## Scout Leader Cook-Off

Unit leaders start leafing through your recipe books today! On Wednesday unit leaders will gather with their ingredients to begin cooking the top culinary Dutch oven meal at Camp Resolute

Prior to camp the Unit Leader may purchase no more than twenty-dollars (\$20) in food and presentation products to create their creation. If you have a favorite Dutch oven bring it along with you, however, we do have some if you need to borrow ours.

At 2:00 cooking will begin and must conclude by 4:30. A select group of Camp Resolute staff members will serve as judges for this competition. The Cook-Off crown will be awarded to the King or Queen of the competition at the closing campfire.

## Unit Accounts

Unit accounts are not available at camp.

## Advancement Awards

Advancement awards, badges of rank, Reso-

lute awards, merit badges that have been offered at camp, etc., will be available from the Trading Post. The Trading Post will also have the mile swim and polar bear awards for the Scouts who have earned them. B.S.A. Lifeguard awards and C.O.P.E. awards will be presented at the Friday night campfire.

## Order of Taunkacoo

At the end of the week, the Scouts in your unit should elect one honor camper through a private ballot managed by the Unit Leader. Unit Honor Campers are usually those Scouts that best exemplify the Scout Oath and Law. Unit Leaders, notify the Administration by lunch on Friday who your honor camper is, while keeping it a secret from the rest of the unit. Recipients will be honored at the Friday evening campfire.

## Discipline in Areas

Each Area Director has been instructed to implement discipline in their area as long as it agrees with BSA and Knox Trail Policies. Leaders will be notified of any discipline issues and together, with the Area Director and/or Program Director, decide upon any discipline to be taken. If you have any problems with the decision made, please see the Camp Director.

## New Program Idea?!?!

Got an idea for a new program? Talk to the area director and Program Director and we'll see what we can do. We're always open to thoughtful suggestions!

## Leader's Lounge

As a special treat for the leaders in camp the Administration Building features several couches for leaders to use to relax and "get away from it all." Complimentary beverages and wireless internet access is also provided as well as plugs to charge computer and cell phone batteries.

# Program Related Information

## Flag Ceremonies in your Campsite

We strongly urge each troop to have a formal Flag Raising and Retreat each day in the campsite. Scouting does not approve of rigid militarism or of stuffy formality, but these ceremonies should be conducted with a dignity and order fitting our respect of the American Flag. It is recommended that the Flag Raising be conducted immediately before the troop leaves for breakfast, and the Retreat before leaving for the campwide Retreat.

## Planning the Troop Program

The basic principle of Scouting is that boys teach boys. This is the ideal in the Troop and is the ideal in camp. Your own older boys should do as much instruction in camp as possible, especially in basic Scout skills. In camp, of course, we have a trained staff who are able to do all the teaching — but think how much better off your Troop would be if you used our staff to train your trainers, rather than doing the job themselves. Remember the proverb, “If you give a man a fish, you feed him for a day. If you teach him to fish, you feed him for life.” Keep this in mind as your Troop plans its program, especially in step 5 below.

A good Scoutmaster does not run his Troop — he helps the boys run their Troop. As your Troop Leaders’ Council plans the camp program, remember that it is their Troop, and they should be able to do what they want and need. Your guidance and suggestions are important, and they need them — but even if you might rather do it a different way, let them do it theirs. Help them avoid the big mistakes that would cut down on their fun at camp, but let them make little mistakes, because they will learn from them. (What we adults think are mistakes might not really be, anyway!)

There are seven simple steps to good program planning:

1. **Explain to the Scouts what the camp has to offer.** Review this manual with them, and let them share their own past experiences at camp.

2. **Determine what your Scouts NEED.** Camporee results, recent Troop programs, and your advancement records will be your most valuable tools in finding out what they need for advancement.
3. **Determine what your Scouts WANT.** Have the Patrol Leaders find out what the boys in their Patrols want to do, and have them report at the Troop Leaders’ Council meeting. Some things they will want to do on their own, some by Patrol, some by Troop, and some with the whole camp. A balanced mix of all 4 is best.
4. **Plan what to do.** In a Troop Leaders’ Council meeting, list all the ideas on which they have agreed. Be sure to allow enough free time for the individual boys to meet their own needs and wants.
5. **Make preliminary instructor assignments.** Decide which program items you want your own boys to lead, and determine who the leaders will be. If they need training or “brush-up”, be sure to arrange to do it or to have our staff do it.
6. **Just before camp, finalize your plans.** After you have completed the preliminary plans, you may find that new ideas have come up or that there are changes which the boys would like to make. Hold a Troop Leaders’ Council meeting a week or so before leaving to review the program and to make any last-minute changes. Schedule your program day-by-day, but not minute-by-minute. Adjustments in schedule will probably be desirable when you get to camp, anyway.
7. **When to sign-up.** Troops can sign up for program at your pre-camp meeting on the Wednesday before you come to camp, and at the Leaders’ meeting on Sunday of your stay.

A GOOD PROGRAM IS A FLEXIBLE PROGRAM.

*Don't miss out on a good opportunity because it crops up at a time that you are too tightly scheduled to take advantage of it!!*

# Program Areas



## 2009 Program at Camp Resolute

- 41 Merit Badges during 3 Morning Merit Badge including
- 6 Program Areas offering over 30 afternoon activities a day! Not even including the specialty programs!
- Scoutcraft, Waterfront, Ecology, Resolute Arts Center, Shooting Sports, and Field Sports (COPE, Climbing and Sports).
- Sports program, offering Athletics and Sports. Afternoon Program including Mountain Biking, and Sport Competitions.
- Older Scout opportunities such as BSA Lifeguard, COPE, Advanced Sailing, and enhanced Mountain Man Program!
- OA Brotherhood induction offered by Chippanyonk Lodge
- Resolute Recruits! first year camper program area.
- And much, much more!

## How It Works

Each area in camp offers a different program. In the morning every area offers 3 periods of merit badges. The afternoons at Camp Resolute offer two activity periods. During these periods, Scouts have the opportunity to participate in a wide variety of activities covering all the program areas in camp, from Ecology to the Rifle Range, to the Waterfront. Each area is open to Scouts for additional merit badge work and assistance, to build skills in a specific area (such as instructional swim), or for the special interest program. Scouts do not have to pre-register for additional merit badge assistance or skill building time. The Scout should schedule those times with the counselor directly.

Registration for the special interest program is done on a daily basis. Scouts can sign up for activities on a unit, patrol or individual basis. The objective is for each Scout to be given the opportunity to take part in those activities that are of interest to him. Activity sessions cover a variety of top-

ics in each program area.

Here is an introduction to the 6 program areas:

## Waterfront

**Merit Badges:** Lifesaving, Swimming, Rowing, Canoeing, and Small Boat Sailing

**Afternoon periods might include:** Instructional Swimming & Boating, Snorkeling, Aqua-Sports, Advanced Swimming & Boating Skills, and Kayaking.

**Special Programs include:** BSA Lifeguard, Snorkeling BSA, Kayaking BSA

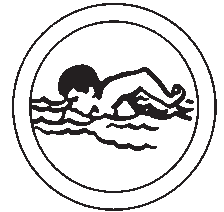

## Ecology

**Merit Badges:** Environmental Science, Fish & Wildlife Management, Mammal Study, Oceanography, Forestry, Soil and Water Conservation, Space Exploration, and Astronomy.

**Afternoon periods might include:** Conservation Projects, 5-mile Hike, Tracking and Casting, Nature Walk, Soil & Water Conservation, Edible Plants Demonstration, Hornaday Conservation Award, Ice Cream Glaciers and Astronomy.



## Shooting Sports

**Merit Badges:** Archery, Rifle Shooting, and Shotgun Shooting

**Afternoon periods might include:** Open Shoot, Best Shot Competition, Inter-Troop Rifle Shoot, and Inter-Troop Archery Shoot

**Special programs:** Mountain Man



# Program Areas

## Scoutcraft



**Merit Badges:** Metalworking, Wilderness Survival, Indian Lore, Camping, Fishing, Orienteering, Cooking, Pioneering, Fire Safety, First Aid, Emergency Prep. and Fly Fishing

**Afternoon periods might include:** Staff Carving, Dream Catchers, Shelter Building, Edible Plants, advanced outdoors cooking, and edible ants!

## Field Sports

**Merit Badges:** Sports, Athletics, Climbing.

**Afternoon periods might include:** Mountain Biking, Bike Maintenance, Basketball game, free-throw Competitions, Volleyball game, soccer game

**Special Programs include:** Inter-troop competitions



## Resolute Arts Center



**Merit Badges:** Art, Basketry, Leatherwork, Music, Pottery, Sculpture, Theater, Fingerprinting and Woodcarving

**Afternoon periods might include:** Tie Dying, Plastic Lace (Gimp), Creative Painting, Whittling and Whittlin' Chit, Sound Works and Clay Sculpture



# Afternoon Activities

## Opportunities Abound

In the afternoon, Camp Resolute becomes a hub of skill development and fun. We continue to build the Scout's citizenship, character, and fitness through two periods of afternoon activities that take place in the various program areas. We also offer specialty programs for adults, older Scouts, and younger Scouts alike.

## Mountain Biking

We once again bring to you Resolute Mountain Biking. Every day we will bring you a different challenge on the back trails of Resolute. Those that participate will receive training in the operation and safety of the bike. All Scouts who wish to participate must go through a bike orientation, which will be offered once every afternoon. Any participants who wish to bring their own bike to camp must have it inspected by the **Sports coordinator** and it will be secured for safety and security.

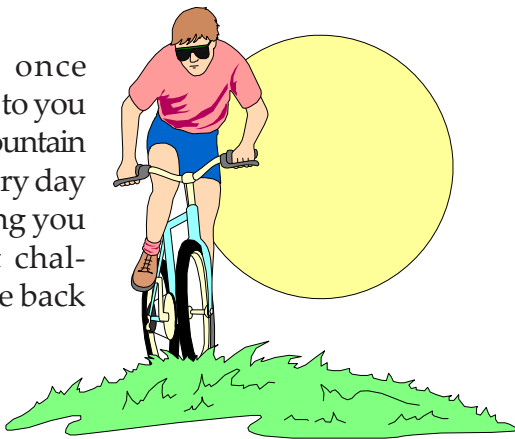

## BSA Snorkeling

This very popular afternoon activity is offered through the Waterfront. This class will allow the participant to achieve the BSA Snorkeling award. Participants may bring their own snorkeling gear or use gear provided by the camp.



## Golf Merit Badge



This merit badge is offered during the afternoon periods Monday thru Thursday. Scouts will receive instruction on Monday and will be transported to a local golf course on Tuesday thru Thursday. An additional fee will apply to this merit badge to cover greens fees. Club rentals are also available for an additional fee.

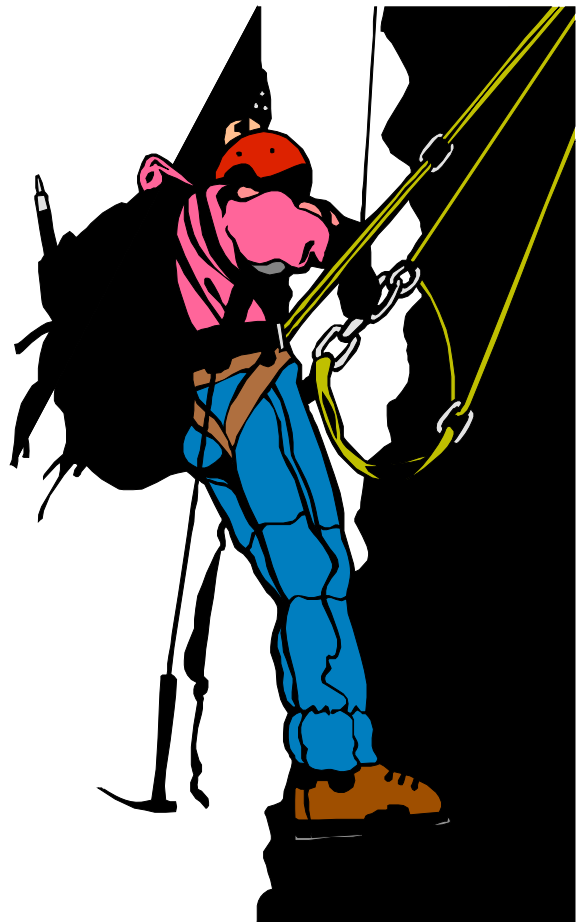

# Older Scout Opportunities

## C.O.P.E.

C.O.P.E. (Challenging Outdoor Personal Experience) is a program designed to teach self-confidence, trust and teamwork. It is a program that challenges Scouts to work closely together throughout the week building a strong team spirit as they work to accomplish a series of physical and mental challenges. The highlight of the program is the challenging high ropes confidence course. The C.O.P.E. program is offered in the afternoon. It will require all afternoon periods for the duration of the week. The age requirement this summer is Scouts must be 13 years of age by January 1, 2009 to partici-

Goals for Project C.O.P.E. fall under seven guidelines:

- Leadership development
- Problem solving
- Communication
- Self-esteem
- Trust
- Decision making
- Teamwork

These fall under both low and high elements on Resolute's own C.O.P.E. course. Think you might have Scouts interested? Sign up during the Wednesday pre-camp meeting.



pate in this program. Adult volunteers are also invited to participate in the C.O.P.E. program. Special training will be provided for these volunteers to allow them to assist the C.O.P.E. Director in running the program. This training will take place during the week.

## Mountain Man

The Mountain Man Program is back this year. It is based on the Buckskin Games held at the National Jamboree. It will involve instruction over the course of the week in black powder rifle shooting, action archery, bowie knife throwing, tomahawk throwing and kabour tossing. The instruction in these pioneer skills will culminate in the Mountain Man Rendezvous at the end of the week. Mountain Man will take place during the afternoon activity sessions from 2:00 PM to 3:00 PM. There will also be activities related to the Mountain Man Program held during the early evenings. It should be noted that this program will be conducted and supervised by trained staff members and adult volunteers. Safety will be stressed above all else. The minimum age for boys to participate is 13 or have completed the 7th grade, and a recommendation from the unit leader is also required. For safety reasons, this program is limited to sixteen (16) participants.

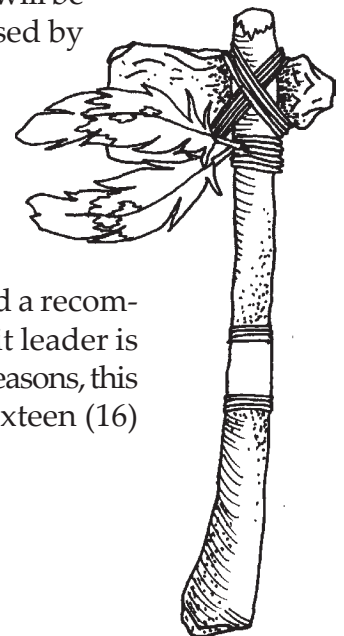

# Older Scout Opportunities

## BSA Lifeguard



This program is for boys and leaders ages 14 and older (Scouts under the age of 14 cannot be certified as lifeguards). A real benefit for all troop water activities this program is one of the most demanding physical and mental tests that Scouting has to offer! Fewer Scouts receive BSA Lifeguard than do Eagle Scout. All candidates are required to cover Polar Bear swim and spend all afternoon on the waterfront to complete the certification. First Aid and CPR are required for certification and are available at a nominal cost to Scouts during the week at camp. Considered equal and more challenging to other Guard certifications by professional organizations (YMCA, American Red Cross, etc.), this is one Certification that is worth the work! Certification is acceptable for employment as a lifeguard. Come and take the challenge!

## Quartermaster Equipment

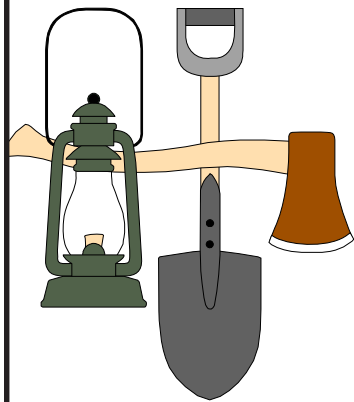

**C a m p  
Resolute has a  
well-stocked  
Quartermaster  
Store which is  
a “lending  
library” for  
e q u i p m e n t  
and supplies.**

**Camp equipment such as Dutch ovens, water jugs, shovels, rakes, and other miscellaneous cooking gear. The Camp Commissioner staff will assist you in locating certain supplies or necessary items to keep your campsite looking ship-shape.**

## Evening Programs & Opportunities After Dark

### Witches Den

Is your unit's leadership looking for something special for your boys? Take advantage of the forgotten fire ring, the Witches Den. Ideal for small groups (no larger than 40) with an out of the way ring that provides your unit the time for your own program. Contact the Program Director for possibilities including staff help, Smores, special presentations, and more!



### Night Hike

For this great opportunity we offer units a chance to get a guided journey around the camp along the trails to wonderful areas that you never knew existed! What a nice way to close the day by seeing secret spots perfect for an astronomy lesson. Contact the Program Director for details.

### Stories

Here we present some of our best story tellers to tell the tales of Resolute. From the founding of the camp to the scary stuff, this is something for thought! Perhaps match with a hike down the tressel to add to the tale? Not for the light of mind. Contact the Program Director for details.

# Resolute Recruits - First Year Camper Program

---

## Resolute Recruits

There are three main objectives to the first year camper program that the campers will achieve. They are (1) Fun (2) Advancement (3) Safety.

This first year camper program will be more hands-on and fun for the Scouts, the main goal of this program is to ensure that the Scouts have fun and at the same time learn new skills. This program will not be class-room based, instead it will be more fun and hands-on, the Scouts will want to come to this program and they will not have to be forced by their Scoutmasters to go like in past years.

### *Purpose*

The purpose of the first year camper program is to give first year campers the foundation of Scouting skills and to teach them things they will remember for the rest of their lives.

### *Procedure*

There will be a designated area strictly for first year camper program, the Scouts will meet there to learn Scout skills and have fun in a safe environment. Here will be able to work on Scout skills like Totin' Chip and Firem'n Chit, and many fun camp games. We will be visiting different program areas throughout the week so the campers can be exposed to different aspects of camp and learn things they may not be able to if they go to these areas alone. There will be active involvement in the program by the staff members of the areas in which we visit.

### *Skills to be Learned*

- Totin' Chip
- Firem'n Chit
- Basic knots
- Fire building
- Cooking of some sort
- Fishing
- Hiking
- Basic first aid
- Having fun at camp

- Many more in each program area.

## How the day will run

### *Morning*

The first year Scouts will be encouraged to take merit badges from a designated list of merit badges that have been selected as adequate merit badges for first year Scouts. This will give the first year Scout the opportunity to gain 3 merit badges during his stay at camp, and also by encouraging them to partake in these merit badges from the list they will develop a strong foundation for their Scouting career and also their Trail to Eagle.

Suggested merit badges include:

- First Aid
- Swimming
- Fishing
- Sports
- Nature
- Woodcarving
- Leatherwork
- Mammal Study
- Cooking
- Archery

### *Afternoon*

During the first 2 afternoon periods we will be visiting a different program area each day and learn skills and having fun involving the things we learned. For example: at the waterfront we will learn basic swimming techniques and after that we will have races to test the endurance of the Scouts and they will have a great time doing it. The last afternoon period is reserved for the first year Scouts to come to the area and get help with their merit badges.

# Evening Programs & Opportunities After Dark

## Monday Aquatics Meet

This event is held weekly on Monday. From Canoe Swamping to relay races, this is one event guaranteed to get you soaked! Come on down for this patrol led competition and see who is the fairest of all the mermen, and perhaps, who is the best patrol of the water!

## Tuesday Night Vespers & Troop Night & Pizza Nite

Following dinner we will have a Scout's Own "vespers" service at the Memorial Chapel at 6:45pm followed by troop night. Troop Night gives a troop an evening to setup a special program, hold a PLC meeting, host an intertroop campfire, or enjoy a watermelon as a troop. If you need assistance planning something special, want to invite your Scout's favorite staff member, or need some help with the activity and would like to have some staff give a helping hand contact the Program Director for possibilities.



Troop swim will begin 15 minutes after the Vespers and will continue for 30 minutes unless daylight ends.

Troops will have the opportunity to order pizza and soda for their troops at a nominal cost and have it delivered to your campsite.

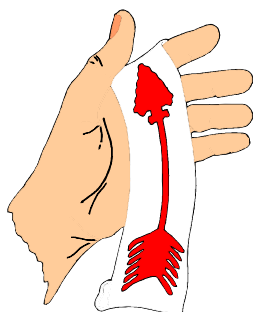

## Order of the Arrow Day

On Wednesdays all OA members are asked to wear their sashes to dinner and to partake in the special event(s) taking place. There will also be an opportunity for eligible

Ordeal Members to seal their membership in the lodge by completing their Brotherhood (Knox Trail Council members only). Make sure that the OA members of your unit are 'prepared' to participate in this event.

## Wednesday's Resolute Quest for Postseason Glory!

This brand new campwide event will test your patrols Scout skills, camp knowledge and provide a great deal of fun. Be set for the race of your life!

**UPDATE!**  
**UPDATE!**  
**UPDATE!**

## Thursday Night Apache Relay

Tradition holds true for the greatest competition ever to grace the shores of Little Pond. Join with a unit team, create an inter-troop team, or just come down and join the festivities to see the "The Apache Relay" 4 runners, 2 canoers, 1 rower, 1 passenger, and 3 swimmers combine to make any team one to be reckoned with. Think you're ready for the big leagues? Challenge the staff to the race!

Thursday's night free swim will begin 15 minutes after the Apache and will continue for 30 minutes unless daylight ends.

## Friday Night Closing Campfire

Bringing to you the very best in campfire entertainment, the Camp Resolute Staff! See the staff and your Scouts perform outrageous skits, song, and cheer in front of a live audience including parents and friends!!!



# Special Programs

## Polar Bear Swim

We're up at 6:50am. How bout you and your Scouts! Come on down to the Waterfront for the daily polar bear plunge! Come Monday through Thursday and be eligible for the Polar Bear Club patch! 6:50 AM, on the dot! Be there! If any leaders or older Scouts would like to volunteer and assist the Waterfront staff in this fantastically early morning activity, feel free to come on down! Leaders please keep track of your scouts and be aware that Polar Bear Swim ends at 7:05 AM.



## Friendship Campfires



To promote friendship and Scouting fellowship, unit leaders are encouraged to host a Friendship Campfire in their campsites.

It's easy! It's fun! And your Scouts will take

home a special memory from camp.

Here's what you do...

- ◆ Determine that your Scouts are interested in hosting a campfire.
- ◆ Invite a troop to your site for a campfire
- ◆ Feel free to invite staff to your campfire, they like to perform.
- ◆ Plan a short program to have fun and promote fellowship.

## Little Pond Triathlon

This event will take place on Friday afternoon and will involve swimming, biking, and running. Scouts wishing to participate will need to condition during the week. Completed entry form due by Friday breakfast.

## Intertroop & Staff Challenges

The staff is raring to get into gear for the season. They have been working out in the off-season getting ready. Want to show that unit from out of town a thing or two? Talk to the Program Director and, challenge them!

*Note about staff challenges - We ABSOLUTELY LOVE challenges! Its what the staff lives for! When a challenge is offered we often find it hard to decline, yet we must also make it work with the program. Because of the depth of Resolute Program we may ask for a postponement to a time more convenient to the staff. Happy Challenging!*

## Order of Taunkacoo VIP Luncheon



If you've received the Order of Taunkacoo Honor Camper award at Camp Resolute then you are invited to the Order of Taunkacoo VIP Luncheon. The luncheon will be held in the training room beneath the Dining Hall during lunch on Thursday. All honor camper recipients should meet there for the meal, which will be waited by the Program Director. All attendees will receive a special desert as well as a special gift. This is our chance to honor you again for the great example you set for your fellow scouts!

## Scout Leader Cook-Off

Unit leaders start leafing through your recipe books today! On Wednesday unit leaders will gather with their ingredients to begin cooking the top culinary Dutch oven meal at Camp Resolute

Prior to camp the Unit Leader may purchase no more than twenty-dollars (\$20) in food and presentation products to create their creation. If you have a favorite Dutch oven bring it along with you, however, we do have some if you need to borrow ours.

At 2:00 cooking will begin and must conclude by 4:30. A select group of Camp Resolute staff members will serve as judges for this competition. The Cook-Off crown will be awarded to the King or Queen of the competition at the closing campfire.

# Advancement & Merit Badges

## Advancement Steps

All advancement at Camp Resolute is accomplished by the same methods that are standard in the BSA. Advancement is accomplished through 4 distinct steps:

1. **Learning:**  
A Scout learns by doing. He learns outdoor skills by hiking and camping. He learns Scout skills in Patrol and Troop sessions. He advances naturally by doing things with his fellow Scouts.
2. **Testing:**  
A Scout demonstrates his ability to members of the Patrol Leaders' Council or other Troop staff members.
3. **Reviewing:**  
The board of review is conducted by the Patrol Leaders' Council or by three or more members of the Troop Committee. The board of review for Star, Life and Eagle will usually occur when a troop returns home. If there are enough bona fide members of a Troop Committee in camp, then this step may be accomplished in an outdoor setting.
4. **Awarding:**  
The Scout is "recognized" in front of his fellow members for his accomplishments. Merit badges and Badges of Rank should be awarded as soon as possible after a Scout is reviewed. Merit Badges will be available at camp for purchase in the Trading Post. Advancement forms are required.

Advancement can and should be a big part of your troop's program. By taking "inventory" of your troop's advancement needs and building the troop and patrol programs around these needs, advancement will be a natural result of a Scout's participation in that program. Special help is avail-

able for training - not examination - on advancement skills through the various camp program activity areas and personnel. Be sure that each Scout takes his Handbook to camp.

## Skills

Scouts will have many opportunities to work on skill requirements. Scouts can be assisted with the "learning" phase of Scout advancement by members of the camp staff. The primary responsibility for reviewing these skills belong to the troop leadership.



## The Resolute Merit Badge Program

Once more Camp Resolute is adding to our wide array of Merit Badges. Badges such as Astronomy will be offered to those Scouts who desire such an opportunity. All of the regular array of badges is offered.

Every merit badge counselor in camp has gone through a week of training in his or her area. They are using the National Camp School Syllabi or their own syllabi approved for use by the Program Director and Camp Director. Occasionally, you as a leader may be of assistance to the merit badge if it is in your area of expertise. We invite you to help (we're never one to refuse help!). Please see the Area Director of the merit badge if you feel you may be of assistance and are willing to lend a helping hand. Any questions about the merit badge

# Advancement & Merit Badges

**UPDATE !  
UPDATE !  
UPDATE !**

or its instruction should go through the following channels: Merit Badge counselor, Area Director, and Program Director.

Each Scout will be challenged to pass their merit badges during their week at camp, however, we cannot guarantee that a Scout will complete the requirements. If for any reason it appears that a Scout will not be able to complete a merit badge the counselor may contact you so that there are no surprises for the Scout. If you have a question as to why a Scout is not being signed off on a requirement please see the Merit Badge Counselor. If you are not satisfied please see the area director or program director and we will meet and discuss the requirements. You will be notified of any disciplinary action by the counselor at their earliest convenience.

## Independent Study Merit Badges

Some merit badges are offered to Scouts through independent study. It is highly suggested that any Scout who decides to take an Independent Study merit badge only take one badge per week. This opportunity has been designed for older Scouts who need less guidance in the completion of a merit badge, and possess the initiative required to complete a badge largely on their own. These badges are offered outside of the normal morning periods and are offered pending availability of counselors.

Examples are Geology, Bird Study, Insect Study, Nature, Bugling, and Hiking. Contact the Program Director for more information or counselor availability.

## Pre-Camp Merit Badge Requirements

The following is a list of the merit badges offered at camp along with the corresponding pre-camp requirements.

Please consult the merit badge pamphlets for specific information about these requirements.

### Archery

prerequisite: none

recommended: 2nd year camper

pre-camp requirement(s): read pamphlet before 1st class

class limit: 18 Scouts

### Art

prerequisite: none

recommended: any Scout

pre-camp requirement(s): 4

### Astronomy

prerequisite: none

recommended: any Scout

pre-camp requirement(s): 6

### Athletics

prerequisite: begin training

recommended: any Scout

pre-camp requirement(s): 3, 5

### Basketry

prerequisite: none

recommended: any Scout

pre-camp requirement(s): none

cost: two basket kits, stool kit

### Camping

prerequisite: provide own equipment for 7b

recommended: any Scout

pre-camp requirement(s): 9a, 9b & 9c

### Canoeing

prerequisite: "swimmer" classification

recommended: Scout must be big enough to carry a canoe alone

pre-camp requirement(s): none

### Climbing

prerequisite: review merit badge pamphlet

recommended: must be 13 years or older as of January 1, 2009

pre-camp requirement(s): none

class limit: 12 Scouts

### Cooking

prerequisite: none

recommended: 2nd year camper

pre-camp requirement(s): 7

class limit: 18 Scouts

# Advancement & Merit Badges

---

## Emergency Preparedness

prerequisite: earn First Aid Merit Badge  
recommended: at least 2nd year camper  
pre-camp requirement(s): 2c, 8c

## Environmental Science

prerequisite: none  
recommended: at least 2nd year camper  
pre-camp requirement(s): 3a, 3b, 3c, 3d, 3e, 3f, 4

## Fingerprinting

prerequisite: none  
recommended: any Scout  
pre-camp requirement(s): none

## Fire Safety

prerequisite: none  
recommended: 2nd year camper  
pre-camp requirement(s): 11

## First Aid

prerequisite: none  
recommended: 2nd year camper  
pre-camp requirement(s): 1, 2d

**UPDATE !  
UPDATE !  
UPDATE !**

## Fish & Wildlife Management

prerequisite: none  
recommended: at least 2nd year camper  
pre-camp requirement(s): 5, 7, 8

**UPDATE !  
UPDATE !  
UPDATE !**

## Fishing

prerequisite: may bring your own equipment  
recommended: any Scout  
pre-camp requirement(s): none

## Fly Fishing

prerequisite: may bring your own equipment  
recommended: any Scout  
pre-camp requirement(s): none

## Golf

prerequisite: none  
recommended: 2nd year camper  
cost: approximately \$55 for greens fees. Club rentals are extra.

## Indian Lore

prerequisite: none  
recommended: any Scout  
pre-camp requirement(s): prepare for req. 1

## Leatherwork

prerequisite: none  
recommended: any Scout  
pre-camp requirement(s): none  
class limit: 20

## Lifesaving

prerequisite: "swimmer" classification  
recommended: at least 2nd year camper, Swimming MB  
pre-camp requirement(s): 1a

**UPDATE !  
UPDATE !  
UPDATE !**

## Mammal Study

prerequisite: none  
recommended: good for 1st year camper  
pre-camp requirement(s): none

## Metalwork

prerequisite: bring workpants (jeans) and closed toe shoes  
recommended: at least 2nd year camper  
cost: metalworking kit - \$8 at trading post  
class limit: 12 Scouts

## Music

prerequisite: must bring instrument  
recommended: 2nd year Scout  
pre-camp requirement(s): 3

## Oceanography

prerequisite: none  
recommended: at least 2nd year camper  
pre-camp requirement(s): research for 8c

## Orienteering

prerequisite: none  
recommended: at least 2nd year camper  
pre-camp requirement(s): none

## Pioneering

prerequisite: none  
recommended: Scout with knowledge of basic knots  
pre-camp requirement(s): none

# Advancement & Merit Badges

---

## Pottery

prerequisite: none  
recommended: any Scout  
pre-camp requirement(s): 7  
cost: purchase clay kit at trading post \$3

## Rifle Shooting

prerequisite: read pamphlet before 1st class **UPDATE!**  
**UPDATE!**  
**UPDATE!**  
recommended: 2nd year Scout with some shooting ability  
pre-camp requirement(s): none  
class limit: 24 Scouts

## Rowing

prerequisite: "swimmer" classification  
recommended: Scout should be sufficient size and strength to carry and handle a boat  
pre-camp requirement(s): none

## Sculpture

prerequisite: none  
recommended: 2nd year Scout  
pre-camp requirement(s): none  
cost: purchase clay kit at trading post \$8

## Shotgun Shooting

prerequisite: age 14 **UPDATE!**  
recommended: 3rd year camper **UPDATE!**  
pre-camp requirement(s): 1f **UPDATE!**  
class limit: 10 Scouts

## Small Boat Sailing

prerequisite: "swimmer" classification  
recommended: prior knowledge of sailing and knots helps  
pre-camp requirement(s): none  
class limit: 12 Scouts

## Soil & Water Conservation

prerequisite: none  
recommended: 2nd year camper  
pre-camp requirement(s): 7

## Space Exploration

prerequisite: none  
recommended: 2nd year camper

pre-camp requirement(s): none  
cost: model rocket kit

## Sports

prerequisite: none  
recommended: 2nd year camper  
pre-camp requirement(s): 4, 5

**UPDATE!**  
**UPDATE!**  
**UPDATE!**

## Swimming

prerequisite: "swimmer" classification, bring long pants and long sleeve shirt  
recommended: good for 1st year camper  
pre-camp requirement(s): 3  
class limit: 24 Scouts

## Theater

prerequisite: none  
recommended: 2nd year Scout  
pre-camp requirement(s): 1  
class limit: 12 Scouts

## Wilderness Survival

prerequisite: none  
recommended: any Scout  
pre-camp requirement(s): 5

## Wood Carving

prerequisite: none  
recommended: any Scout  
pre-camp requirement(s): none

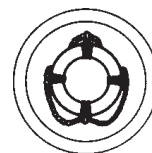

# Camp Resolute Daily Schedule

**MEAL TIMES:** Breakfast: 7:00am to 8:00am      Lunch: 12:15pm      Dinner: 5:30pm

## MONDAY - FRIDAY

6:50am	Polar Bear Swim
7:00am	Reveille
7:00am	Breakfast Buffet Begins
8:00am	Breakfast Buffet Ends
8:15am	Resolute Good Turn/Site Clean-Up
8:40am	Morning Colors
9:00am	First Merit Badge Period
10:00am	Second Merit Badge Period
10:00am	Leaders' Meeting
11:00am	Third Merit Badge Period
11:50am	Program Areas Closed
12:00pm	Waiter's Report to Dining Hall
12:15pm	Lunch
1:00pm	Siesta
2:00pm	Afternoon Activity Period I
3:00pm	Afternoon Activity Period II
4:00pm	Open Program
4:45pm	Troop Time
5:15pm	Waiters Report to Dining Hall
5:15pm	Colors
5:30pm	Dinner
6:45pm	Camp Wide Program
10:00pm	Taps

In addition.....

<b>MONDAY</b>	6:45pm	Aquatics meet
<b>TUESDAY</b>	6:45pm	Vespers (remember a Scout is Reverent)
	7:30pm	Troop Night
<b>WEDNESDAY</b>	6:45pm	Resolute Quest for Post Season Glory
	8:15pm	Order of the Arrow Event
<b>THURSDAY</b>	6:45pm	Apache Relay
<b>FRIDAY</b>	3:00pm	Leader's Meeting & Paperwork Processing
	4:00pm	Troop Awards in Campsites
	6:30pm	Family Chicken BBQ
	7:15pm	Formal Parade and Retreat
	8:00pm	Closing Campfire

# Camp Resolute Sunday Schedule

## SUNDAY

1:00pm	All Troops Sign-In
1:30-5:00pm	Intro on Dining Hall. Take swim tests and health check.
5:00pm	Troop Photos
5:45pm	Formal Parade and Retreat
6:00pm	Dinner
7:40pm	All Camp Meeting on Parade Field followed by Waterfront Orientation
8:15pm	Opening Campfire
10:00pm	Taps



# Camp Resolute 2009 Schedule

TIME	MONDAY	TUESDAY	WEDNESDAY	THURSDAY	FRIDAY
6:45	Polar Bear Swim	Polar Bear Swim	Polar Bear Swim	Polar Bear Swim	Polar Bear Swim
7:00	Reveille	Reveille	Reveille	Reveille	Reveille
7 to 8	<b>BREAKFAST</b>	<b>BREAKFAST</b>	<b>BREAKFAST</b>	<b>BREAKFAST</b>	<b>BREAKFAST</b>
8:40	Morning Colors	Morning Colors	Morning Colors	Morning Colors	Morning Colors
9:00	Merit Badge Period I	Merit Badge Period I	Merit Badge Period I	Merit Badge Period I	Merit Badge Period I
10:00	Merit Badge Period II Leader's Meeting	Merit Badge Period II Leader's Meeting	Merit Badge Period II Leader's Meeting	Merit Badge Period II Leader's Meeting	Merit Badge Period II Leader's Meeting
11:00	Merit Badge Period III	Merit Badge Period III	Merit Badge Period III	Merit Badge Period III	Merit Badge Period III
12:15	<b>LUNCH</b>	<b>LUNCH</b>	<b>LUNCH</b>	<b>LUNCH</b>	<b>LUNCH</b>
1:00	Siesta	Siesta	Siesta	Siesta	Siesta
2:00	Afternoon Activity I	Afternoon Activity I	Afternoon Activity I	Afternoon Activity I	Leader's Meeting
3:00	Afternoon Activity II	Afternoon Activity II	Afternoon Activity II	Afternoon Activity II	Free Time
4:00	Open Program	Open Program	Open Program	Open Program	Troop Awards
4:45	Troop Time	Troop Time	Troop Time	Troop Time	In Campsite
5:15	Colors	Colors	Colors	Colors	
5:30	<b>DINNER</b>	<b>DINNER</b>	<b>DINNER</b>	<b>DINNER</b>	Family BBQ (6:30)
6:45	Aquatics Meet	Vespers	Resolute Challenge	<b>APACHE</b>	Formal Parade & Retreat
8:00	Troop Time	Troop Night	Troop Time	<b>RELAY</b>	Closing Campfire
10:00	Taps	Taps	Taps	Taps	Taps



# Camp Resolute

## 2009 Merit Badge Schedule

TIME	SCOUTCRAFT	ECOLOGY	ARTS CENTER	WATERFRONT	RANGES	FIELD SPORTS
9:00 to 9:50	Camping Wilderness Surv. Fishing Indian Lore First Aid	Environmental Sci. Mammal Study Space Exploration	Open period for these badges Pottery Leatherwork Music	Canoeing Rowing Swimming	Archery Rifle Shooting	Emergency Prep. (Big Top)
9:00 to 10:50				Lifesaving		
10:00 to 10:50	Cooking Orienteering Pioneering First Aid	Environmental Sci. Fish & Wildlife Mgt. Forestry	Open period for these badges Sculpture Basketry Fingerprinting	Canoeing Swimming	Archery Rifle Shooting	Athletics (Ball Field)
10:00 to 11:50				Small Boat Sailing		Climbing (Big Top)
11:00 to 11:50	Fire Safety Camping Fly Fishing Cooking	Astronomy Oceanography Soil & Water Cons.	Open period for these badges Art Woodcarving Theater	Canoeing Swimming Kayaking BSA*	Rifle Shooting Shotgun Shooting	Sports (Ball Field)

\*This is an award not a merit badge



## Camp Resolute Honor Patrol Application

Troop # and Town \_\_\_\_\_ Council \_\_\_\_\_  
Patrol Name \_\_\_\_\_ Camp Week \_\_\_\_\_  
Patrol Leader \_\_\_\_\_  
Scoutmaster \_\_\_\_\_

*The Honor Patrol Award will be made to each patrol that meets the following requirements:*

- ◆ The patrol must have four or more patrol members in camp.
- ◆ The patrol leader must register his patrol at the camp office by 5pm Monday.
- ◆ The patrol must keep a log of patrol activities during the week; it should be on 8-1/2 x 11 sheets of paper in a diary form and not just timetable. The senior patrol leader and the Scoutmaster must check the log on Wednesday during siesta for a preliminary review, and on Friday for the final check.
- ◆ As a patrol, do a distinctive service for Camp Resolute as approved by the Program Director. A preliminary check will be made Wednesday. The project must be completed by lunch on Friday for final approval.  
Project: \_\_\_\_\_
- ◆ Cooperate with other patrols of the Troop in planning and conducting at least one troop campfire program. In the log, details must be included of the part the patrol was responsible for and successfully completed.
- ◆ The patrol must plan and carry out an effective patrol schedule utilizing the opportunities of the troop scheduled activities and camp program areas to the patrol's best advantage, including attending a camp afternoon program each day.
- ◆ The troop leader must approve and sign this form, as evidence that the patrol has participated in the whole troop program to his/her satisfaction and that the objectives have been met.
- ◆ Attend at least one afternoon program each day.  
Monday: \_\_\_\_\_ Tuesday: \_\_\_\_\_ Wednesday: \_\_\_\_\_ Thursday: \_\_\_\_\_
- ◆ Participate in the Resolute Quest for Postseason Glory as a patrol.

**NOTE: This application is due by lunch Friday.**

**This patrol has qualified for the Honor Patrol Award in all requirements listed above, and as evidenced by our signatures.**

Patrol Leader \_\_\_\_\_

Scoutmaster \_\_\_\_\_

Approved by:  
Program Director \_\_\_\_\_

Date \_\_\_\_\_ Week \_\_\_\_\_



## Camp Resolute Honor Troop Application

Troop # and Town \_\_\_\_\_ Council \_\_\_\_\_

Number of Patrols in Camp \_\_\_\_\_ Camp Week \_\_\_\_\_

Scoutmaster \_\_\_\_\_

*Camp Honor Troop is a high honor based on assessment of three areas:*

### Patrols

- ◆ All Patrols must have earned the Honor Patrol Award
- ◆ The troop must hold at least one Patrol Leader’s Council meeting during their stay at camp.

### Advancement

- ◆ The troop must meet its advancement objectives to the satisfaction of the Program Director.

### Activities

The Troop must:

- ◆ Participate in all camp wide activities (games and activities, vespers and campfires).
- ◆ Conduct at least one Troop campfire program during the week (The program should exhibit scout spirit and live up to the high ideals of the Scout Oath, Law, Motto, and Slogan.).
- ◆ Campsite must pass inspection 4 of 5 days.

**NOTE: This application is due in addition to the Honor Patrol Applications by lunch Friday.**

**Troop # \_\_\_\_\_ has completed all of the requirements for the Camp Resolute Honor Troop Award**

**Scoutmaster \_\_\_\_\_**

**Senior Patrol Leader \_\_\_\_\_**

Approved by:

Program Director \_\_\_\_\_

Date \_\_\_\_\_ Week \_\_\_\_\_

## Implementation of new required CORI background checks

The Massachusetts Department of Public Health made changes to the summer camp regulations to make sure that the laws that relate to all Children's Camps comply with Chapter 385 Legislation of the Acts of 2002. The legislation requires all camps in Massachusetts to obtain Criminal Offender Record Information (CORI) data for all staff and volunteers, regardless of age, prior to employment or **volunteer service**. The Department of Public Health has made the determination that all volunteer leaders coming to camp with their own troops fall into the category of camp volunteers and must complete a background check prior to their arrival at camp.

**What does this mean to your troop? In order for your troop to comply you must provide us a list of all volunteers and parents, registered and unregistered, that will be coming with your troop to camp this summer in any capacity other than visitor.** We also strongly encourage you to include those parents and leaders that could potentially come to camp and stay as a leader (if a leader must leave camp due to an emergency the only person who could take their place is someone who has already had a background check through Camp Resolute). Additionally, the list must be provided to us no later than **June 1<sup>st</sup>** so that we have time to forward the list to the Criminal History Systems Board (CHSB) for processing. We have been told that we should expect the background checks to take a minimum of 2-3 weeks for them to be completed. **All volunteers must be checked prior to their arrival at camp.**

***Who do you really need to include?*** All leaders that will be staying in camp overnight, who will be staying for any length of time during the day, or know they will be coming into camp on a regular basis must be checked. In other words, if you have a parent that will be "filling in" while another leader goes to work then they must be included in the check. A parent dropping off a watermelon, a committee member coming in for a board of review, or someone just visiting for a short while does not have to have a background check. Essentially, if the person is in camp, and they are not a camper or short time visitor, they must be checked.

***What are some of the consequences?*** One example is that your troop will not be allowed to have any "drop-in" overnight guests that have not had a background check completed. In the past, for example, some troops might have a college student or parent come to visit for a few hours and then they decide that they would like to stay for the entire day or even overnight. **By state law we cannot allow this to happen.**

***Do we need signed permission from the individual to submit their name for the CORI check?*** **No.** The new law does not require that we obtain a signature of the individual prior to having a CORI conducted. We do recommend, however, that you at least notify the individual that a CORI will be conducted.

***What if I have completed a background check through another organization, group or school?*** The law does not allow for sharing of these records between organizations. You will be required to complete a background check for every organization in which you volunteer.

***What happens to the information collected?*** All collected information will be kept locked and will be used only for CORI reporting.

***What information will be returned as a result of the check and what happens if negative information is returned?*** We will receive records of all adult and juvenile arrests, convictions, non-convictions, and pending criminal case data (not things like parking tickets). The Boy Scouts of America has guidelines of which offenses are automatically excluded from participation in our programs. Additionally, the Commonwealth of Massachusetts has recommendations of which offenses should be excluded from participation. All returned information is only available to be reviewed by certified staff, including the Scout Executive, and determinations for participation shall be made on a case-by-case basis.

***What is the next step?*** Attached you will find a sheet asking for volunteers' name (including maiden name and aliases), phone number, date of birth, social security number, and current address. Use as many sheets as necessary. If you prefer you can send us a printout as long as it includes the same information. **Return this information to no later than June 18<sup>th</sup>** to:

Knox Trail Council, BSA  
Attention: CORI  
490 Union Avenue  
Framingham, MA 01702

I hope this answers most of the questions that might arise. ***The intention of this law is simple – to help protect our kids.*** Please help us keep all of our Scouts safe. If you have any additional questions or concerns please feel free to contact Rick Riopelle at (508) 872-6551 or via email at [ktcprogram@rickapelle.com](mailto:ktcprogram@rickapelle.com).

2009 CAMP RESOLUTE  
All Troop Adult Volunteers Attending Camp

**Information collected for the purposes of Massachusetts CORI reporting  
All Information to be kept in strictest confidence**

TROOP and TOWN \_\_\_\_\_ DATES IN CAMP \_\_\_\_\_

-----  
First Name \_\_\_\_\_ Last Name \_\_\_\_\_

Alias/Maiden Name \_\_\_\_\_ Phone Number \_\_\_\_\_

Date of Birth \_\_\_\_\_ Social Security # \_\_\_\_\_

Address (Street, Town, ZIP) \_\_\_\_\_

-----  
First Name \_\_\_\_\_ Last Name \_\_\_\_\_

Alias/Maiden Name \_\_\_\_\_ Phone Number \_\_\_\_\_

Date of Birth \_\_\_\_\_ Social Security # \_\_\_\_\_

Address (Street, Town, ZIP) \_\_\_\_\_

-----  
First Name \_\_\_\_\_ Last Name \_\_\_\_\_

Alias/Maiden Name \_\_\_\_\_ Phone Number \_\_\_\_\_

Date of Birth \_\_\_\_\_ Social Security # \_\_\_\_\_

Address (Street, Town, ZIP) \_\_\_\_\_

-----  
First Name \_\_\_\_\_ Last Name \_\_\_\_\_

Alias/Maiden Name \_\_\_\_\_ Phone Number \_\_\_\_\_

Date of Birth \_\_\_\_\_ Social Security # \_\_\_\_\_

Address (Street, Town, ZIP) \_\_\_\_\_

-----  
First Name \_\_\_\_\_ Last Name \_\_\_\_\_

Alias/Maiden Name \_\_\_\_\_ Phone Number \_\_\_\_\_

Date of Birth \_\_\_\_\_ Social Security # \_\_\_\_\_

Address (Street, Town, ZIP) \_\_\_\_\_

**Knox Trail Council, BSA**  
**490 Union Ave.**  
**Framingham, MA 01702**

**Outdoor Fire Policy**

The purpose of the Outdoor Fire Policy stated below is to limit the size of all outdoor fires used in conjunction with BSA related program elements on properties owned and operated by the Knox Trail Council, Boy Scouts of America.

The rationale for this policy is summarized as follows;

- To protect the health and safety of all Scouts, Scouters and visitors participating in programs requiring the use of a fire or fires on the aforementioned properties.
- To reduce the risk of damage to the property as well as the properties of our abutting neighbors and the associated liability resulting from such damage.
- To conform to state fire regulations as they pertain to outdoor fires.
- To conform to all EPA and OSHA regulations as pertaining to outdoor burning and incineration of materials that may be considered hazardous.

**Outdoor Fire Policy**

**1. Fire Lay**

No fire lay in excess of 6' in diameter and 5' in height will be permitted on properties owned and operated by the Knox Trail Council, BSA without the express written permission of the Council Camping Committee and the appropriate property superintendent (Ranger/Caretaker).

The Ranger/Caretaker will have the right to restrict the use of fires on the property for whatever reason deemed appropriate.

**2. Combustibles**

All combustibles used in construction of any fire lay for use with Scouting related program element will be natural and clean. Combustibles that have been contaminated by paint, solvents, creosote or other preservative chemicals may not be used.

**3. Fire Starters/Accelerants**

In accordance with BSA policy, *the use of liquid or chemical fuels to start or accelerate any fire is prohibited.*

Approved: 5/27/97  
Council Camping Committee

# Annual Health and Medical Record

(Valid for 12 calendar months)

## Medical Information

The Boy Scouts of America recommends that all youth and adult members have annual medical evaluations by a certified and licensed health-care provider. In an effort to provide better care to those who may become ill or injured and to provide youth members and adult leaders a better understanding of their own physical capabilities, the Boy Scouts of America has established minimum standards for providing medical information prior to participating in various activities. Those standards are offered below in one three-part medical form. Note that unit leaders must always protect the privacy of unit participants by protecting their medical information.

**Parts A and C** are to be completed annually **by all BSA unit members**. Both parts are required for all events that do not exceed 72 consecutive hours, where the level of activity is similar to that normally expended at home or at school, such as day camp, day hikes, swimming parties, or an overnight camp, and where medical care is readily available. Medical information required includes a current health history and list of medications. Part C also includes the parental informed consent and hold harmless/release agreement (with an area for notarization if required by your state) as well as a talent release statement. Adult unit leaders should review participants' health histories and become knowledgeable about the medical needs of the youth members in their unit. This form is to be filled out by participants and parents or guardians and kept on file for easy reference.

**Part B** is required with parts A and C for any event that exceeds 72 consecutive hours, a resident camp setting, or when the nature of the activity is strenuous and demanding, such as service projects, work weekends, or high-adventure treks. It is to be completed and signed by a certified and licensed health-care provider—physician (MD, DO), nurse practitioner, or physician's assistant as appropriate for your state. The level of activity ranges from what is normally expended at home or at school to strenuous activity such as hiking and backpacking. Other examples include tour camping, jamborees, and Wood Badge training courses. It is important to note that the height/weight chart must be strictly adhered to if the event will take the unit beyond a radius wherein emergency evacuation is more than 30 minutes by ground transportation, such as backpacking trips, high-adventure activities, and conservation projects in remote areas.

## Risk Factors

Based on the vast experience of the medical community, the BSA has identified that the following risk factors may define your participation in various outdoor adventures.

- Excessive body weight
- Heart disease
- Hypertension (high blood pressure)
- Diabetes
- Seizures
- Lack of appropriate immunizations
- Asthma
- Sleep disorders
- Allergies/anaphylaxis
- Muscular/skeletal injuries
- Psychiatric/psychological and emotional difficulties

For more information on medical risk factors, visit Scouting Safely on [www.scouting.org](http://www.scouting.org).

## Prescriptions

The taking of prescription medication is the responsibility of the individual taking the medication and/or that individual's parent or guardian. A leader, after obtaining all the necessary information, can agree to accept the responsibility of making sure a youth takes the necessary medication at the appropriate time, but BSA does not mandate or necessarily encourage the leader to do so. Also, if state laws are more limiting, they must be followed.



BOY SCOUTS OF AMERICA

# Commonwealth of Massachusetts Immunization Requirements

105 CMR 430.152

Written documentation of immunization or alternative proof of immunity shall be required for all campers, adults, and staff as follows:

## For Campers and Staff under 18 Years Old

- 1) **Measles, Mumps and Rubella (MMR) Vaccine:** A minimum of one dose of MMR vaccine(s) must be administered at or after 12 months of age. A second dose of live measles containing vaccine given at least four weeks after the first, is required for all campers and staff, who will be entering grades K-12 or college in the school year immediately following the camp session (or in case of an ungraded classroom or the camper/staff does not attend school/college, campers or staff five years of age or older). Laboratory evidence of immunity is acceptable.
- 2) **Polio Vaccine:** A minimum of three doses of either inactivated polio vaccine (IPV) or oral polio vaccine (OPV) are required. If a mixed (IVP/OPV) schedule was used, four doses are required;
- 3) **Diphtheria and Tetanus Toxoids and Pertussis Vaccine:** A minimum of four doses of DTaP/DTP/DT or at least three doses of Td is required. Where a camper or staff person is seven or more years of age and requires additional immunizations to satisfy 105 CMR 430.152(A)(3), Td is to be substituted for DTaP, DTP or DT vaccine. Effective January 1, 2004, a booster dose of Td is required for all campers and staff who will be entering grades seven through ten (or in the case of an ungraded classroom or the camper or staff does not attend school, campers or staff 12 through 15 years of age) if it has been more than five years since the last dose of DTaP/DTP/DT. For all campers and staff who will be entering grades 11 and 12 (or in the case of an ungraded classroom or the camper or staff does not attend school, campers or staff 16 through 17 years of age) a booster of Td is required if it has been more than ten years since the last dose of DTaP/DTP/DT/Td.
- 4) **Hepatitis B:** For all children born on or after January 1, 1992, three doses of Hepatitis B vaccine are required. Laboratory evidence of immunity is acceptable.

## For Staff and Adults 18 Years of Age or Older

- 1) **Measles Vaccine:** Unless born before 1957, two doses of live measles-containing vaccine administered at/or after 12 months of age (at least four weeks apart) are required. Laboratory evidence of immunity is acceptable.
- 2) **Mumps Vaccine:** Unless born before 1957, at least one dose of mumps vaccine administered at/or after 12 months of age is required. Laboratory evidence of immunity is acceptable.
- 3) **Rubella Vaccine:** Unless born before 1957, at least one dose of rubella vaccine administered at/or after 12 months of age is required. Laboratory evidence of immunity is acceptable.
- 4) **Diphtheria and Tetanus Toxoids:** At least three doses of DTaP/DTP/DT/Td are required. A booster dose of tetanus/diphtheria, adult type toxoid (Td) is required if more than ten years have elapsed since the last dose of DTaP/DTP/DT/Td vaccine.

## Physical Examinations or Immunizations Excepted (105 CMR 430.153)

- 1) **Religious Exceptions:** If a camper or staff member has religious objections to physical examinations or immunizations, the camper or staff member shall submit a written statement, signed by a parent or legal guardian for those under 18 years of age, to the effect that the individual is in good health and stating the reason for such objections.
- 2) **Immunizations Contraindicated:** Any immunization specified in 105 CMR 430.152 shall not be required if the health history required by 105 CMR 430.151 includes a certification by a physician that he or she has examined the individual and that, in the physician's opinion, the physical condition of the individual is such that his or her health would be endangered by such immunization.

# Annual BSA Health and Medical Record

## Part A

### GENERAL INFORMATION

Name \_\_\_\_\_ Date of birth \_\_\_\_\_ Age \_\_\_\_\_ Male  Female   
 Address \_\_\_\_\_ Grade completed (youth only) \_\_\_\_\_  
 City \_\_\_\_\_ State \_\_\_\_\_ Zip \_\_\_\_\_ Phone No. \_\_\_\_\_  
 Unit leader \_\_\_\_\_ Council name/No. \_\_\_\_\_ Unit No. \_\_\_\_\_  
 Social Security No. (optional; may be required by medical facilities for treatment) \_\_\_\_\_ Religious preference \_\_\_\_\_  
 Health/accident insurance company \_\_\_\_\_ Policy No. \_\_\_\_\_

**ATTACH A PHOTOCOPY OF BOTH SIDES OF INSURANCE CARD (SEE PART C).  
 IF FAMILY HAS NO MEDICAL INSURANCE, STATE "NONE."**

### In case of emergency, notify:

Name \_\_\_\_\_ Relationship \_\_\_\_\_  
 Address \_\_\_\_\_  
 Home phone \_\_\_\_\_ Business phone \_\_\_\_\_ Cell phone \_\_\_\_\_  
 Alternate contact \_\_\_\_\_ Alternate's phone \_\_\_\_\_

### MEDICAL HISTORY

Are you now, or have you ever been treated for any of the following:

Yes	No	Condition	Explain
		Asthma	
		Diabetes	
		Hypertension (high blood pressure)	
		Heart disease (i.e., CHF, CAD, MI)	
		Stroke/TIA	
		COPD	
		Ear/sinus problems	
		Muscular/skeletal condition	
		Menstrual problems (women only)	
		Psychiatric/psychological and emotional difficulties	
		Learning disorders (i.e., ADHD, ADD)	
		Bleeding disorders	
		Fainting spells	
		Thyroid disease	
		Kidney disease	
		Sickle cell disease	
		Seizures	
		Sleep disorders (i.e., sleep apnea)	
		GI problems (i.e., abdominal, digestive)	
		Surgery	
		Serious injury	
		Other	

### Allergies or Reaction to:

Medication \_\_\_\_\_  
 Food, Plants, or Insect Bites \_\_\_\_\_

### Immunizations:

The following are recommended by the BSA. Tetanus immunization must have been received within the last 10 years. If had disease, put "D" and the year. If immunized, check the box and the year received.

Yes	No	Date
<input type="checkbox"/>	<input type="checkbox"/>	Tetanus _____
<input type="checkbox"/>	<input type="checkbox"/>	Pertussis _____
<input type="checkbox"/>	<input type="checkbox"/>	Diphtheria _____
<input type="checkbox"/>	<input type="checkbox"/>	Measles _____
<input type="checkbox"/>	<input type="checkbox"/>	Mumps _____
<input type="checkbox"/>	<input type="checkbox"/>	Rubella _____
<input type="checkbox"/>	<input type="checkbox"/>	Polio _____
<input type="checkbox"/>	<input type="checkbox"/>	Chicken pox _____
<input type="checkbox"/>	<input type="checkbox"/>	Hepatitis A _____
<input type="checkbox"/>	<input type="checkbox"/>	Hepatitis B _____
<input type="checkbox"/>	<input type="checkbox"/>	Influenza _____
<input type="checkbox"/>	<input type="checkbox"/>	Other _____

Exemption to immunizations claimed.  
**(For more information about immunizations, as well as the immunization exemption form, see Scouting Safely on Scouting.org.)**

### MEDICATIONS This section not for use at Camp Resolute - Use separate authorization form.

List all medications currently used. (If additional space is needed, please photocopy this part of the health form.) Inhalers and EpiPen information must be included, even if they are for occasional or emergency use only.

Medication _____ Strength _____ Frequency _____ Reason for medication _____ Approximate date started _____ Temporary <input type="checkbox"/> Permanent <input type="checkbox"/>	Medication _____ Strength _____ Frequency _____ Reason for medication _____ Approximate date started _____ Temporary <input type="checkbox"/> Permanent <input type="checkbox"/>	Medication _____ Strength _____ Frequency _____ Reason for medication _____ Approximate date started _____ Temporary <input type="checkbox"/> Permanent <input type="checkbox"/>
Medication _____ Strength _____ Frequency _____ Reason for medication _____ Approximate date started _____ Temporary <input type="checkbox"/> Permanent <input type="checkbox"/>	Medication _____ Strength _____ Frequency _____ Reason for medication _____ Approximate date started _____ Temporary <input type="checkbox"/> Permanent <input type="checkbox"/>	Medication _____ Strength _____ Frequency _____ Reason for medication _____ Approximate date started _____ Temporary <input type="checkbox"/> Permanent <input type="checkbox"/>

**NOTE: Be sure to bring medications in the appropriate containers, and make sure that they are NOT expired, including inhalers and EpiPens. You SHOULD NOT STOP taking any maintenance medication.**

Emergency contact No.:

Allergies:

DOB:

Last name:



## Part B

### PHYSICAL EXAMINATION

Height \_\_\_\_\_ Weight \_\_\_\_\_ Meets height/weight limits  Yes  No Blood pressure \_\_\_\_\_ Pulse \_\_\_\_\_

**Individuals desiring to participate in any high-adventure activity or events in which emergency evacuation would take longer than 30 minutes by ground transportation will not be permitted to do so if they exceed the weight limit as documented at the bottom of this page. Enforcing the height/weight limit is strongly encouraged for all other events, but it is not mandatory. (For healthy height/weight guidelines, visit [www.cdc.gov](http://www.cdc.gov).)**

	Normal	Abnormal	Explain Any Abnormalities	Range of Mobility	Normal	Abnormal	Explain Any Abnormalities
Eyes				Knees (both)			
Ears				Ankles (both)			
Nose				Spine			
Throat							
Lungs				<b>Other</b>	<b>Yes</b>	<b>No</b>	
Heart				Contacts			
Abdomen				Dentures			
Genitalia				Braces			
Skin				Inguinal hernia			<b>Explain</b>
Emotional adjustment				Medical equipment (i.e., CPAP, oxygen)			

**Allergies** (to what agent, type of reaction, treatment):

I certify that I have, today, reviewed the health history, examined this person, and approve this individual for participation in:

- Hiking and camping     Competitive activities     Backpacking     Swimming/water activities     Climbing/rappelling  
 Sports     Horseback riding     Scuba diving     Mountain biking     Challenge ("ropes") course  
 Cold-weather activity (<10°F)     Wilderness/backcountry treks

Specify restrictions (if none, so state)

**Certified and licensed health-care providers recognized by the BSA to perform this exam include physicians (MD, DO), nurse practitioners, and physician's assistants.**

- To Health Care Provider:** Restricted approval includes:
- Uncontrolled heart disease, asthma, or hypertension.
  - Uncontrolled psychiatric disorders.
  - Poorly controlled diabetes.
  - Orthopedic injuries not cleared by a physician.
  - Newly diagnosed seizure events (within 6 months).
  - For scuba, use of medications to control diabetes, asthma, or seizures

Provider printed name \_\_\_\_\_  
 Signature \_\_\_\_\_  
 Address \_\_\_\_\_  
 City, state, zip \_\_\_\_\_  
 Office phone \_\_\_\_\_  
 Date \_\_\_\_\_

Height (inches)	Recommended Weight (lbs)	Allowable Exception	Maximum Acceptance
60	97-138	139-166	166
61	101-143	144-172	172
62	104-148	149-178	178
63	107-152	153-183	183
64	111-157	158-189	189
65	114-162	163-195	195
66	118-167	168-201	201
67	121-172	173-207	207
68	125-178	179-214	214
69	129-185	186-220	220

Height (inches)	Recommended Weight (lbs)	Allowable Exception	Maximum Acceptance
70	132-188	189-226	226
71	136-194	195-233	233
72	140-199	200-239	239
73	144-205	206-246	246
74	148-210	211-252	252
75	152-216	217-260	260
76	156-222	223-267	267
77	160-228	229-274	274
78	164-234	235-281	281
79 & over	170-240	241-295	295

This table is based on the revised Dietary Guidelines for Americans from the U.S. Dept. of Agriculture and the Dept. of Health & Human Services.

**Part B** Last name: \_\_\_\_\_ DOB: \_\_\_\_\_

**Part C**

**Informed Consent and Hold Harmless/Release Agreement**

I understand that participation in Scouting activities involves a certain degree of risk. I have carefully considered the risk involved and have given consent for myself and/or my child to participate in these activities. I understand that participation in these activities is entirely voluntary and requires participants to abide by applicable rules and standards of conduct. I release the Boy Scouts of America, the local council, the activity coordinators, and all employees, volunteers, related parties, or other organizations associated with the activity from any and all claims or liability arising out of this participation.

I approve the sharing of the information on this form with BSA volunteers and professionals who need to know of medical situations that might require special consideration for the safe conducting of Scouting activities.

In case of an emergency involving me or my child, I understand that every effort will be made to contact the individual listed as the emergency contact person. In the event that this person cannot be reached, permission is hereby given to the medical provider selected by the adult leader in charge to secure proper treatment, including hospitalization, anesthesia, surgery, or injections of medication for me or my child. Medical providers are authorized to disclose to the adult in charge examination findings, test results, and treatment provided for purposes of medical evaluation of the participant, follow-up and communication with the participant's parents or guardian, and/or determination of the participant's ability to continue in the program activities.

- Without restrictions.
- With special considerations or restrictions (list)

**Talent Release Form**

I hereby assign and grant to the local council and the Boy Scouts of America the right and permission to use and publish the photographs/film/videotapes/electronic representations and/or sound recordings made of me or my child by the Boy Scouts of America, and I hereby release the Boy Scouts of America from any and all liability from such use and publication.

I hereby authorize the reproduction, sale, copyright, exhibit, broadcast, electronic storage, and/or distribution of said photographs/film/videotapes/electronic representations and/or sound recordings without limitation at the discretion of the Boy Scouts of America, and I specifically waive any right to any compensation I may have for any of the foregoing.

- Yes  No

**I understand that, if any information I/we have provided is found to be inaccurate, it may limit and/or eliminate the opportunity for participation in any event or activity.**

Participant's name \_\_\_\_\_

Participant's signature \_\_\_\_\_

Parent/guardian's signature \_\_\_\_\_  
(if under the age of 18)

Date \_\_\_\_\_

**Attach copy of insurance card (front and back) here. If required by your state, use the space provided here for notarization.**



BOY SCOUTS OF AMERICA  
1325 West Walnut Hill Lane  
P.O. Box 152079  
Irving, Texas 75015-2079  
<http://www.scouting.org>



2008 Printing

**Part C**    **Last name:** \_\_\_\_\_    **DOB:** \_\_\_\_\_

**Camp Resolute**  
**Authorization to Administer Medication to a Camper**  
**(To be completed and submitted with medical form)**

I hereby authorize E. Paul Robsham Scout Reservation to administer to my child;

\_\_\_\_\_ the medications listed below in accordance with 105 CMR 430.160.  
 (Name of Child)

List all medications currently used. (If additional space is needed, please photocopy this form.) Inhalers and EpiPen information must be included, even if they are for occasional or emergency use only.

Medication _____ Strength _____ Frequency _____ Reason for medication _____ _____ Approximate date started _____ Temporary <input type="checkbox"/> Permanent <input type="checkbox"/>	Medication _____ Strength _____ Frequency _____ Reason for medication _____ _____ Approximate date started _____ Temporary <input type="checkbox"/> Permanent <input type="checkbox"/>
Medication _____ Strength _____ Frequency _____ Reason for medication _____ _____ Approximate date started _____ Temporary <input type="checkbox"/> Permanent <input type="checkbox"/>	Medication _____ Strength _____ Frequency _____ Reason for medication _____ _____ Approximate date started _____ Temporary <input type="checkbox"/> Permanent <input type="checkbox"/>
Medication _____ Strength _____ Frequency _____ Reason for medication _____ _____ Approximate date started _____ Temporary <input type="checkbox"/> Permanent <input type="checkbox"/>	Medication _____ Strength _____ Frequency _____ Reason for medication _____ _____ Approximate date started _____ Temporary <input type="checkbox"/> Permanent <input type="checkbox"/>

**NOTE: Be sure to bring medications in the original containers, and make sure that they are not expired, including inhalers and EpiPens. You should not stop taking any maintenance medication.**

105 CMR 430.160(A)

*Medication prescribed for campers shall be kept in original containers bearing the pharmacy label, which shows the date of filling, the pharmacy name and address, the filling pharmacist's initials, the serial number of the prescription, the name of the patient, the name of the prescribing practitioner, the name of the prescribed medication, directions for use and cautionary statements, if any, contained in such prescription or required by law, and if tablets or capsules, the number in the container. All over the counter medications for campers shall be kept in the original containers containing the original label, which shall include the directions for use.*

105 CMR 430.160(C)

*Medication shall only be administered by the health supervisor or by a licensed health care professional authorized to administer prescription medications. The health care consultant shall acknowledge in writing the list of medications administered at the camp. If the health supervisor is not a licensed health care professional authorized to administer prescription medications, the administration of medications shall be under the professional oversight of the health care consultant. Medication prescribed for campers brought from home shall only be administered if it is from the original container, and there is written permission from the parent/guardian.*

105 CMR 430.160(D)

*When no longer needed, medications shall be returned to a parent or guardian whenever possible. If the medication cannot be returned, it shall be destroyed.*

Parent/Guardian Signature: \_\_\_\_\_ Date: \_\_\_\_\_



# Camp Resolute Parental Authorization Form

## Compliance with Massachusetts State Law regarding Authorized Use of Firearms by a Minor

The Knox Trail Council adheres to all applicable laws and operates under the governance of BSA National Standards as well as MA State Health Code. As a part of the Boy Scout Program the council operates several safe shooting sports ranges for Scouts to participate in rifle shooting, shotgun, and archery. In order to satisfy Mass General Law Chapter 140 section 130 the council requires parental permission to participate in such activities. Mass General Law Chapter 140, Section 130 stipulates the following:

Furnishing Child 15 or older with Rifle, Shotgun and Ammunition

“Nothing in this section shall be construed to prohibit an instructor from furnishing rifles or shotguns or ammunition to pupils; provided however that said instructor has the **consent of a parent or guardian of a pupil under the age of 18.**”

The pupil must be under the direct supervision of a person (the range instructor) holding a valid Firearms Identification Card or a License to Carry Firearms.

## Photo Release Statement

I hereby assign and grant to the Knox Trail Council the right and permission to use and publish the photographs/film/video tapes/electronic representations and/or sound recordings made during my son’s visit to Camp Resolute by the Knox Trail Council, and I hereby release the Knox Trail Council, Boy Scouts of America from any and all liability from such use and publication. I hereby authorize the reproduction, sale, copyright, exhibit, broadcast, electronic storage and/or distribution of said photographs/film/video tapes/electronic representations and/or sound recordings without limitation at the discretion of the Knox Trail Council and I specifically waive any right to any compensation I may have for any of the foregoing.

\_\_\_\_\_ I hereby authorize my child to participate in all events during summer camp including (if age appropriate) use of the shooting sports program areas (for rifle and shotgun under supervision of a FID instructor) and I agree to the Photo Release Statement outlined above.

\_\_\_\_\_ I do not authorize my child to participate in shooting sports activities. However, my child is authorized to participate in all other events and activities of the camp and I agree to the Photo Release Statement outlined above.

Scout’s Name \_\_\_\_\_

Troop Number \_\_\_\_\_ Town \_\_\_\_\_

Parent/Guardian Signature: \_\_\_\_\_

Date: \_\_\_\_\_

*This form is required for every Scout and must be turned in along with the camp medical form.*



## Camp Resolute Permission Slip for Golf Merit Badge

(to be sent to camp with your Scout)

There will be a charge of approximately \$55 to cover the greens fees for 2 days. Club rentals are available at an additional cost. Your Scoutmaster has the details. If you wish to permit your Scout to participate in this activity, please complete the following permission statement:

"My son \_\_\_\_\_ of Scout Troop# \_\_\_\_\_ of \_\_\_\_\_  
Name Community

has my permission to participate in the Golf Merit Badge program and to leave camp with a qualified driver to get to the golf course."

Parent's Signature \_\_\_\_\_ Date \_\_\_\_\_





# Camp Resolute 2009 Aquatics Meet

This Meet is overseen by the Waterfront Director. Any question concerning ruling must be directed to the Waterfront Director. Final decision on any problem will be settled by a discussion between the Waterfront Director, a Scoutmaster, and the Program Director.

Your patrol competes in a series of competitions at the Waterfront. Points will be awarded according to patrols that place 1<sup>st</sup>, 2<sup>nd</sup>, 3<sup>rd</sup>, and 4<sup>th</sup> in each event. Overall winners will be awarded only for 1<sup>st</sup>, 2<sup>nd</sup>, and 3<sup>rd</sup> place in the overall meet. Please have enough Scouts for all events because the events will begin promptly as each other ends. **Rosters are due at Lunch on Monday.**

Troop # \_\_\_\_\_ Town: \_\_\_\_\_ Patrol Name: \_\_\_\_\_

**Best Dressed** – One member from each patrol will get dressed up as their merman of choice to find out who is crowned King Neptune of the Aquatics Meet. This person will reside at the tower for the remainder of the meet. Points **WILL** be added for creativity

\_\_\_\_\_

**Apache Canoe Fun** – Two swimmers attempt to canoe out to the Apache cove buoy. On the way out, each time a whistle sounds, they must switch places. On the way back from the Apache Cove buoy, each time a whistle sounds, the swimmers must jump in and out of the canoe without swamping.

\_\_\_\_\_

**Kickboard fun** – 5 Scouts from each patrol swim a kickboard to the other side of the beginners pool. The catch is that each member must be touching the kickboard at all times or they must begin again. So, 5 members of the patrol begin on the edge of the beginners area touching both the wall and the kickboard, then they must swim (while still touching the board) to the opposite side. Have fun!

\_\_\_\_\_  
\_\_\_\_\_

**Relay** – Four Scouts will each swim dog paddling one length of the beginners pool.

\_\_\_\_\_  
\_\_\_\_\_

**Big Splash Competition** – One Scout and one Scoutmaster from each patrol swims out to a raft. They then jump off into the swimmer's area. Style, splash, and sound will be factors in judging.

\_\_\_\_\_

## Aquatics MEET 2009!!!





# Apache Relay Rules

## 2009 edition

### Section I: The Course

---

The course consists of 9 segments in which a baton must be passed (not thrown). Each segment must be made in the following sequence only:

1. Runner goes from the front gate of Camp Resolute to the Dining Hall entrance door.
2. Runner goes from the Dining Hall to the Trestle.
3. Runner goes from the Trestle to the Ball Field.
4. Runner goes from the Ball field to the Old Canoe Area.
5. Two canoeists go around a designated buoy to the rowboat.
6. One oarsman and one passenger go around designated buoys to the swimmer's raft (you must back in with care).
7. A swimmer goes from the raft to the dock separating the swimmers' pool from the beginners' pool.
8. A beginner swimmer crosses the beginners' pool to the dock separating the beginners and the non-swimmers' pools.
9. A non-swimmer goes from the dock to the flagpole.

### Section II: The Participants

---

All participants must be less than 18 years of age on the day of the Apache Relay. Any Scout who has paid for a full week of camp may participate regardless of how many nights he stayed in camp. Staff members may not participant on a troop team.

### Section III: Race Restrictions

---

#### Hand-off's

1. The baton must be handed to the next individual within the passing zone as designated by the official.
2. The baton must be handed, not thrown!

#### Runners:

1. All runners must adhere to the designated roads or paths.

#### Old Canoeing Area

1. The runner must adhere to the road that runs in front of the Dining Hall and around the telephone pole closest to the old canoeing area.
2. The runner must run the designated path to the canoes.
3. The runner may not toss the baton to the front of the canoe. Hand it to the Scout in the back of the canoe.
4. The individual in the back of the canoe must be handed the baton. This individual may slide it to the front.
5. The runner may push the canoe off but then must leave the area immediately.

### Rowing Area

1. The individual not rowing is the passenger and must receive the baton from the canoeists.
2. The oars may not in any way be held in the row-locks. This includes, but is not exclusive of, tying, pin, and passenger holding.
3. The rowboat must be backwatered to the raft. Note: The rowboat may lightly tap the raft (advised against) but not ram the dock. The officials on site and the Head Judge will consider decision on said ramming.
4. The Rowboat must not cut into or enter the swimming area in any way. Note: you will not be disqualified if the oar of the rowboat passes into the airspace over the swimmers area, but does not enter the water.
5. The passenger may not help in the actual rowing in any way (however bobbing is allowed) and may not change places. He may provide only verbal guidance to the oarsman.

### Swimming Area

1. When checking in, each participant will obey all directives given by the Waterfront Staff. The non-swimmers will check in according to the buddy system for the safety of all.
2. The swimmers in the beginners and non-swimmers pools must jump feet first into the water.
3. The non-swimmers must check out before leaving the area. His buddy tag must not be defaced in any way.

### **Section IV: The Judges**

---

1. Staff members shall be the only judges in the events.
2. The Program Director or designee shall be the Head Judge.
3. Each team will be notified of any changes (major or minor) in the rules prior to the start of the race.
4. The Head Judge's ruling is final. In the case of a dispute, then the Head Judge may assemble the appropriate officials from the dispute, as well as Scoutmasters from troops involved to discuss the dispute and come to a decision. However, the final decision is in the Head Judge's.

### **Section V: Miscellaneous**

---

1. Anything that injures or causes safety hazards of a party, in the opinion of the officials, is grounds for disqualification.
2. Anything that hinders the advancement of another team in any manner, shape, or form; in the opinion of the judges, is grounds for disqualification.
3. Any infraction of the above rules is grounds for disqualification.
4. Equipment malfunction can not be used to change the results of the race.
5. The baton must be approved by the program director or at the SPL meeting before the Apache Relay
6. If a troop is unable to fill an Apache Relay race roster, they are allowed (upon permission of the Program Director) to solicit other troops for participants. If this fails, or they troop decides against this course of action, they are allowed to have participants in multiple positions as long as no rules of the race are broken. (ex. No Scout could be both a canoeist and a rower. However, a Scout could run and then swim.)
7. Completed rosters are due by lunch on Thursday. No exceptions.



## Apache Relay Race Form

*THIS FORM MUST BE USED. NO OTHER FORM WILL BE ACCEPTED.  
PLEASE WRITE NEATLY AND CLEARLY*

Patrol Name: \_\_\_\_\_ Troop: \_\_\_\_\_  
*"A" OR "B" WILL NOT BE ACCEPTED. MUST HAVE A PATROL NAME LISTED*

Campsite: \_\_\_\_\_

1. Gate to Dining Hall \_\_\_\_\_
2. Dining Hall to Trestle \_\_\_\_\_
3. Trestle to Ball Field \_\_\_\_\_
4. Ball Field to Canoe Area \_\_\_\_\_
5. Canoe Area to Rowboat \_\_\_\_\_  
\_\_\_\_\_
6. Rowboat to Swimmers Raft \_\_\_\_\_  
\_\_\_\_\_
7. Swimmers Raft to Dock \_\_\_\_\_
8. Beginners Pool \_\_\_\_\_
9. Non-Swimmer's to flagpole \_\_\_\_\_



## Camp Resolute 2009 Little Pond Triathlon

---

The Little Pond Triathlon will be held each Friday at 1:30 pm. The Little Pond Triathlon route begins on the Swimmers' Raft. Each athlete will swim to the Cub Adventure Day Camp dock where they will put on their shoes to run through the Apache campsite to the Ball Field. There they will get on their bicycles and race to the finish line located in front of the Health Lodge.

This event helps promote unity not only on a camp-wide basis, but within troops. It directly ties in with Scouting's aim to promote physical fitness in our youth. Scouts will have the opportunity to set a goal, train, and compete with others around the camp.

Safety is very important to all Scouting programs, especially those involving physical competition. At Camp Resolute, the thought-provoking and inspiring slogan "We Do More" is applied to how we handle safety, as well as programs. In the swimming portion of the race, all BSA rules and regulations regarding the waterfront will be in effect. All swimmers must have passed the BSA Swimmer's test, as well as be in proper physical condition to swim across the pond. Each swimmer must provide a rower and guard to be positioned in the pond to assist with the safety of the scouts. At each transition point, a staff member will be positioned to ensure that the rules are being followed and that each scout safely completes that portion of the race. Scouts will be required to wear proper safety equipment and ride only on a bike that has been approved by the head judge of the event. There will be people watching around the camp, so any accidents will be identified immediately and dealt with appropriately. The Health Officer will be on hand in case of any serious accidents.

### **Requirements to compete in the Little Pond Triathlon:**

1. Participants must be in good health and be physically able to swim, run, and bike. This will be judged by the Health Officer and the Scoutmaster.
2. Participants must complete at least two Polar Bear Swim sessions during the week, swimming with those who are preparing for the Mile Swim. Polar Bear Swim is every morning from 6:50am to 7:05am at the Waterfront.
3. Participants must complete at least one session of Personal Training (PT). PT will give each Scout an opportunity to train through a series of calisthenics, running, and muscular exercise.
4. Any bicycle not provided by the camp must be approved by the head judge prior to the start of the race.
5. In accordance with BSA regulations, each participant must provide a rower and a guard to assist them in swimming across the pond.



## Camp Resolute 2009 Little Pond Triathlon

---

Please fill out the following and return to the Camp Resolute Sports Staff *no later than* Friday at breakfast.

Name: \_\_\_\_\_ Age: \_\_\_\_\_

Troop/Town: \_\_\_\_\_

1. Fitness Check: A. \_\_\_\_\_, Camp Health Officer

B. \_\_\_\_\_, Scoutmaster

2. Polar Bear Swim (twice): \_\_\_\_\_, Waterfront Staff

3. Personal Training: \_\_\_\_\_, Sports Staff

4. Bike Check (if applicable): \_\_\_\_\_, Sports Staff

5. Swim Team: A. \_\_\_\_\_, Rower

B. \_\_\_\_\_, Guard

I, \_\_\_\_\_, of Troop \_\_\_\_\_, agree to participate in the *Little Pond Triathlon* with conviction towards Scouting Spirit and sportsmanship. I also agree to swim, run and bike in the name of the Scouting Oath, Law and Motto as a participant.

\_\_\_\_\_  
*Little Pond Triathlon* Participant



## Camp Resolute Campwide Good Turns

Camp-wide good turns are daily services that each troop contributes to the camp in the form of helping to keep the camp clean. Areas of camp are assigned to each unit based on their campsite location. Senior Patrol Leaders will be accountable for their unit's completion of their daily good turn. It is preferred that each unit performs its good turn following breakfast. The good turn only takes a few minutes, and it makes our camp looking its best for everyone who comes to visit!

**Smokey Pines:** Clean the field in front of C.O.P.E. each day.

On **Monday**, clean the Smokey Pines Shower House.

**Cherokee:** Clean the Chapel and the field in front of it each day.

On **Tuesday**, clean the Smokey Pines Shower House.

**Apache:** Clean the left fork trail each day.

On **Wednesday**, clean the Smokey Pines Shower House.

**Char-Mur:** Clean the Ball Field each day.

On **Thursday**, clean the Smokey Pines Shower House.

**Kiowa South:** Clean the Trestle each day.

On **Friday**, clean the Smokey Pines Shower House.

**Kiowa North:** Clean the Blacktop and Picnic Grove each day.

On **Friday**, clean the Smokey Pines Shower House.

**Mitapo:** Clean in front of the Trading Post and its picnic tables each day.

On **Monday**, clean the Sassamon Shower House.

**Nomolos:** Clean the picnic tables next to the Dining Hall on both sides each day.

On **Tuesday**, clean the Sassamon Shower House.

**Sassamon:** Clean the field in front of the Rifle Range each day.

On **Wednesday**, clean the Sassamon Shower House.

**Mohawk:** Clean the right fork trail each day.

On **Thursday**, clean the Sassamon Shower House

**THANK YOU FOR HELPING TO KEEP CAMP RESOLUTE CLEAN!**



## Camp Resolute Camp Rules

Scouts trying to live up to the values of the Scout Oath and Law should have very little trouble following rules based on common sense and good Scouting!

1. Be careful with fire. **NO FLAMES IN TENTS!** NEVER leave a fire unattended. Make sure firepit is cleared for six feet around the fireplace. **ALWAYS** keep water nearby when you have a fire going. NEVER use the Indian pumps for anything other than fire control. These and the rake, shovel, and broom are the primary tools to be used in case a brush/forest fire were to happen in camp. These tools **MUST** be available and functional when needed!
2. Stay out of fenced areas (waterfront, C.O.P.E., ranges) unless given specific permission by a Camp Resolute Staff member to enter. Once given permission, obey the posted rules for that area.
3. Do not leave camp property unless signed out of camp at the Administration Building by a unit leader from your troop.
4. Respect camp property. The beds, mattresses, and tents you use are only loaned to you for your stay in camp. Your unit will be expected to pay for any damage caused to camp equipment by members of your unit. Writing on your tent is considered equivalent to destroying it. Scouts doing the writing will be expected to buy the tent (\$485.00). Mattresses are not to be removed from the tent. If you rip a mattress you will be expected to pay for it (\$75.00).
5. Respect the rights of others. Respect the privacy of other troops in their campsites, day and night. Do not cut through other campsites and maintain silence between taps and reveille (10:00 p.m. – 7:00 a.m.).
6. Scouts are to remain in their own campsites between taps and reveille. Scout showers should be finished early enough to return to campsites before taps (10:00 p.m.).
7. Except while in a tent, in the shower, or at the waterfront, footgear **MUST** be worn at all times.
8. Respect our natural resources. Cut **NO** live trees or plants. Leave wild animals and birds alone- don't try to catch them. Prevent erosion- leaves, needles, and plants should be left where they are. Don't sweep or rake the ground near your tent or in the campsite. (Six- foot clearance circle around the fire pit is an exception.)
9. Keep your body clean; bathe frequently.
10. Keep your mind clean; develop habits of clean speech and thoughts.
11. Keep your property neat and clean in your tent or shelter.
12. Keep your camp/campsite clean. Place all litter in the trash barrels.



## Camp Resolute Daily Campsite Visitation Sheet

TROOP/ TOWN: \_\_\_\_\_ CAMPSITE: \_\_\_\_\_

5= Excellent

3=Good

1=Poor

Tents	M	T	W	Th	F	Total
-------	---	---	---	----	---	-------

1. All flaps up/ rolled inward (in good weather)
2. Floors of tent cleaned (including underneath)
3. Footlocker/ pack neatly stored at end of or under cot
4. Bed made (sleeping rolled in toward top)
5. Clothesline behind tent with no clothes strung on tent

Latrine and Washstand
-----------------------

1. Latrine floor swept
2. Latrine disinfected
3. Toilet paper available
4. Washstand cleaned

Campsite in General
---------------------

1. Firebuckets filled, fireguard chart posted and up to date
2. Bulletin board posted with Troop program, duty rosters, etc.
3. Campsite clean of litter and debris
4. Fire pit/fireplace cleaned
5. All tools stored properly
6. Camp gadgets in campsite (or on trail to campsite)
7. Flagpole flying U.S. flag
8. Flagpole flying Troop flag

Campwide Project
------------------

1. Evidence that campwide project completed
2. Scout spirit in evidence

TOTALS
--------

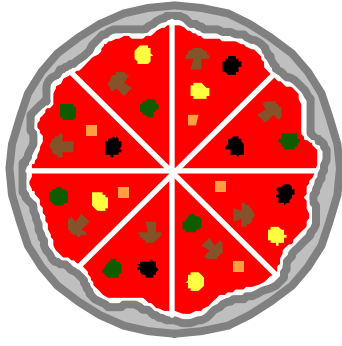

# Pizza

**FOR EVERYONE**

Tuesday Night is Pizza Night!!!!

Troops can order pizza by the Leader's Meeting Monday Morning and have it delivered to your campsite on Tuesday Night between 8 – 8:30pm

Large Cheese Pizza is \$9.25

Large Pepperoni Pizza is \$10.25

2 liters of Soda is \$1.75

Troop \_\_\_\_\_ Site \_\_\_\_\_

Unit Leader \_\_\_\_\_

# of Cheese Pizzas \_\_\_\_\_ @ \$9.25 = \_\_\_\_\_

# of Pepperoni Pizzas \_\_\_\_\_ @ \$10.25 = \_\_\_\_\_

# of 2 liter Coke \_\_\_\_\_ @ \$1.75 = \_\_\_\_\_

# of 2 liter Diet Coke \_\_\_\_\_ @ \$1.75 = \_\_\_\_\_

# of 2 liter Sprite \_\_\_\_\_ @ \$1.75 = \_\_\_\_\_

Total = \_\_\_\_\_



*Napkins and cups provided at no charge.*



# Camp Resolute Platform Tents

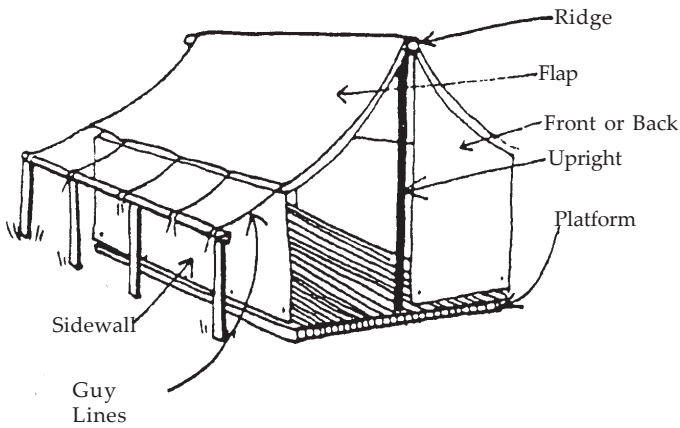

## Tent Care

- Don't write or mark on tent anywhere, even if you see writing
- Never pin or hang anything on your tent
- Tents are not clotheslines!
- Use no sprays inside your tent
- Leave wet canvas alone (don't roll or touch)
- Leave flaps rolled up, unless stormy weather
- Even at night, tent will be more comfortable with flaps up
- Never remove the bunk or mattress from the tent

## How To Roll Up Front or Back Flaps

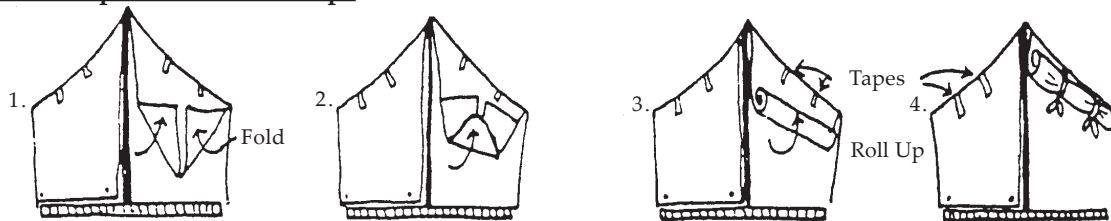

Note: These sketches are views from the inside of your tent

1. Fold corners in neatly
2. Fold the end up neatly
3. Roll up neatly
4. Tie the ends with a bow or 1/2 bow, not a knot of any kind

*Always roll flaps from inside the tent. If you roll on the outside, you create a "gutter" which collects*

## How To Roll Up Sidewalls (A lot easier with more than one person)

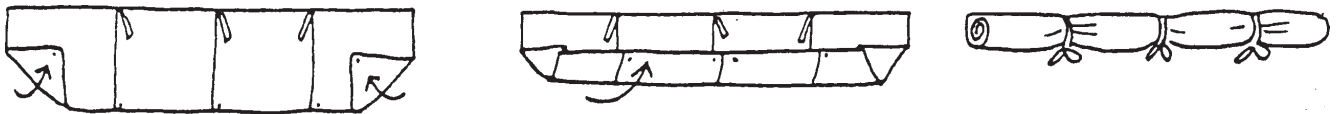

Note: These sketches are views from the inside of your tent

1. Fold corners in neatly
2. Start rolling from the straight edge at the bottom
3. Roll up neatly
4. Tie the tapes with a bow or 1/2 bow, not a knot of any kind

*Always roll flaps from inside the tent. If you roll on the outside, you create a "gutter" which collects*

*Enjoy your tent and week at Camp Resolute!*



# Camp Resolute – Bolton, Massachusetts

Troop \_\_\_\_\_

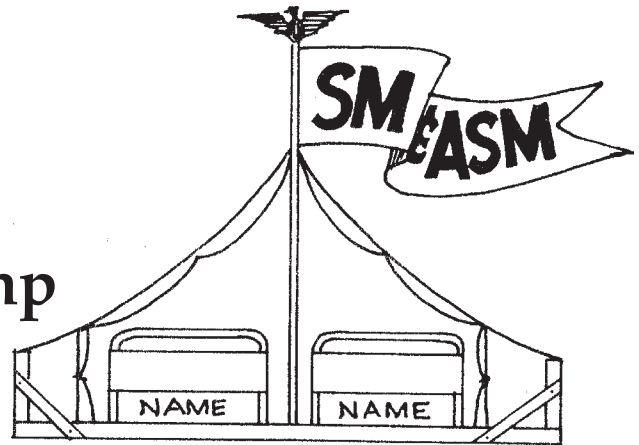

## While We're At Camp

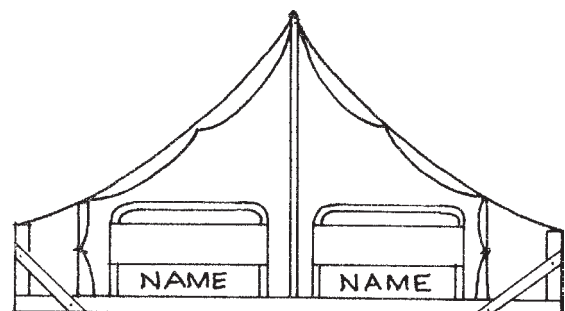
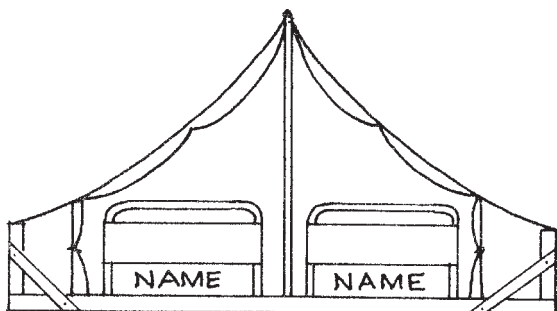
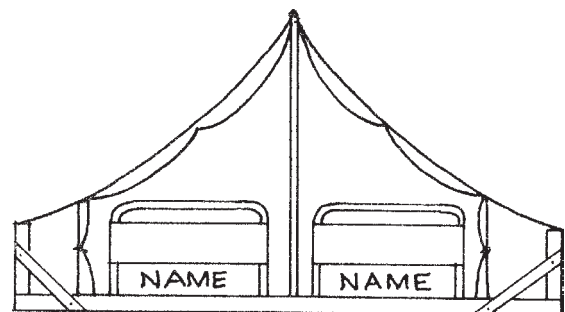
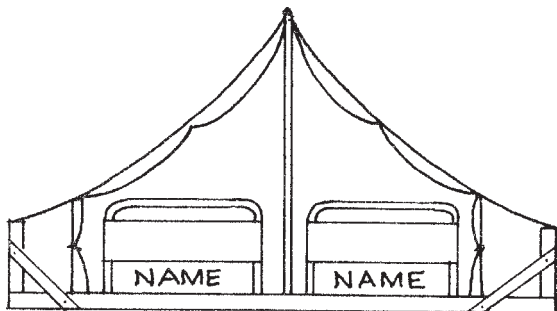
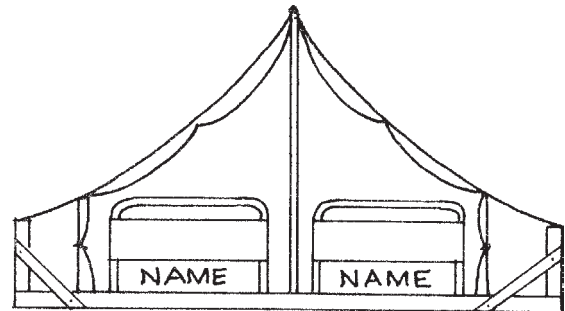
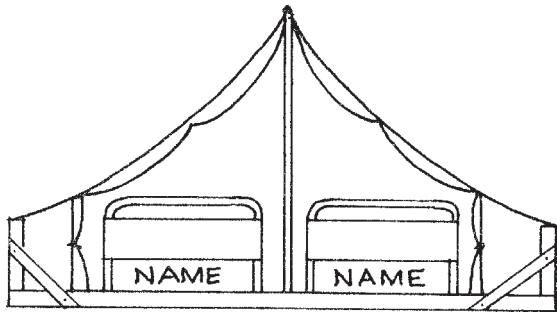
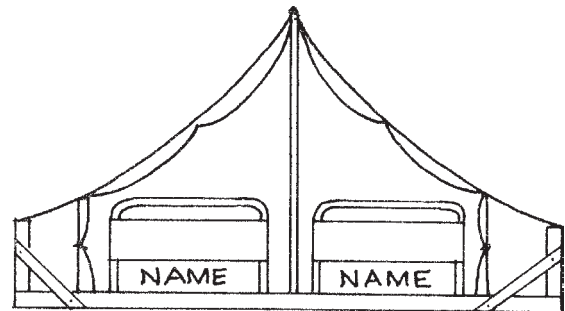
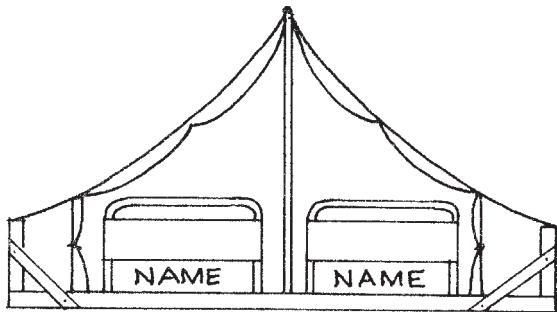



## **Camp Resolute Wildlife Plan**

With the safety of campers, leaders and staff in mind, a few areas have been identified as concerns in terms of wildlife in camp. A number of measures can be taken to prevent both injury and disease that may result in contact with wildlife in camp. Two basic areas should be addressed including animals and insects.

### Wild Animals

Wild Animals such as skunks, raccoons and foxes potentially represent possibility of either injury or rabies. The best possible plan involves prevention of exposure to reduce risk. Preventative measures may include:

- Hiking only on designated trails
- Maintaining a clean campsite
- Storing smellables properly
- Maintaining a distance from animals that may be encountered
- Avoid feeding of animals (both intentionally or not)
- Avoiding direct contact with animals, including new offspring

Any sightings that are recurring should be reported to the unit leadership and administration. This is especially of true nocturnal animals, sighted during the day, which seem to be exhibiting any behavior that may be deemed unusual. In the event of direct contact, particularly a scratch or bite, the Health Officer should be notified immediately.

### Insects

Insects also present the possibility of personal injury but also disease: mosquitoes and ticks present the largest threat. Measures of prevention include regular application of insect repellent and the appropriate clothing being worn on hikes and activities in heavily wooded areas. Both tick and mosquito bites have the potential of transmitting disease to people. While prevention is preferable, insect bites may be unavoidable in certain situations. Any questionable amounts of mosquito bites and embedded ticks should be referred to the Health Officer.

### Awareness

Scouts and their leaders should be aware of the potential hazards that exposure to wild animals. Prevention and awareness is the key to safe camp experience.



# Camp Resolute Scoutmaster Merit Badge

In order to earn the Scoutmaster Merit Badge, a leader must complete six out of the ten items. Once the six items have been completed, have the Camp Director sign your form for final approval.

- 1. Participate in the Scout Leader Cook-Off. \_\_\_\_\_  
Program Director
- 2. Help teach a skill in a merit badge class. \_\_\_\_\_  
Area Director
- 3. Learn a new skill during the week. \_\_\_\_\_  
Senior Patrol Leader
- 4. Attend daily Scoutmaster Meetings. \_\_\_\_\_  
Program Director
- 5. Relax and enjoy yourself. \_\_\_\_\_  
Commissioner
- 6. Help your Scouts learn a new skit or song. \_\_\_\_\_  
Commissioner
- 7. Complete two of the following: Safe Swim Defense, Safety Afloat,  
Climb on Safely, Trek Safely, Youth Protection or CPR. \_\_\_\_\_  
Program Director
- 8. Do one activity at camp you have always wanted to but "never had the time." \_\_\_\_\_  
Senior Patrol Leader
- 9. Troop participates in the Scout Vespers service. \_\_\_\_\_  
Program Director
- 10 Participate in a Friendship Campfire with another unit. \_\_\_\_\_  
Commissioner

\_\_\_\_\_  
Adult Leader Name (Please Print)

\_\_\_\_\_  
Camp Director's Signature

This form must be turned into the Camp Director by lunch on Friday.



## Camp Resolute Graces

---

### **Breakfast**

Gracious giver of all good,  
Thee we thank for rest and food.  
Grant that all we do or say  
In thy service be this day.

### **Lunch**

Father for this noonday meal,  
We would speak the praise we feel.  
Health and strength we have from thee,  
Help us, Lord, to faithful be.

### **Dinner**

Tireless guardian on our way,  
Thou has kept us well this day.  
While we thank thee, we request  
Care continued, pardon, rest.



## Camp Resolute Taunkacoo Honor Camper

At the end of the week, the Scouts in your unit should select one honor camper through a private ballot managed by the Unit Leader. Unit Honor Campers are usually those Scouts that best exemplify the Scout Oath and Law. Unit Leaders, notify the camp administration who your honor camper is, while keeping it a secret from the rest of the unit. Recipients will be honored at the Friday evening campfire.

Troop # \_\_\_\_\_ Town \_\_\_\_\_

The Scouts in our unit have selected the following Scout to receive the Honor Camper award from Camp Resolute:

\_\_\_\_\_

Please provide a brief description for the nomination: \_\_\_\_\_

\_\_\_\_\_

\_\_\_\_\_

\_\_\_\_\_

\_\_\_\_\_

Kindly bring this completed form to the Friday Morning Leader's Meeting!



## Unit Swim Check Procedures

The swim classification of individuals participating in a Boy Scouts of America activity is a key element in both Safe Swim Defense and Safety Afloat. The swim tests should be renewed annually, preferably at the beginning of each outdoor season. Traditionally, swim classification tests have only been conducted upon arrival at summer camp. However, there is no restriction that this be the only place the test is conducted. It may be more useful to conduct the swim classification prior to a unit's arrival at summer camp.

Adopted for the Knox Trail Council's Camp Resolute  
for the 2009 Camping Season.

**\*The Swim Check Administrator MUST be approved by the Knox Trail Council prior to the administration of the Unit Swim Check\***

Special Note: Although swim tests may be conducted prior to summer camp, the aquatics director is expected to review or retest any Scout or Scouter whose skills appear to be inconsistent with his or her classification. Additionally the aquatics program director is authorized to retest any Scout or group of Scouts when he or she is reasonably concerned that pre-camp swim tests were not properly administered.

# Purpose of this Policy

The Knox Trail Council has adopted the Unit Swim Check policy to promote the purposes of BSA aquatics.

The BSA aquatics program has five basic objectives.

- To give youth self-confidence and skill in aquatics
- To instruct youth in self-preservation, the care and use of aquatics equipment and rescue methods
- To promote aquatics recreation
- To develop physical strength and coordination
- To aid units in planning and conducting a safe year-round aquatics program
- 

The unit swim check policy has been established to facilitate the check-in process at summer camp.

**The unit swim check is NOT accepted at summer camp if a Scout is enrolling in an aquatics merit badge.**

If a Scout is enrolling in an aquatics merit badge, they must take the swim test at summer camp under the direction of the summer camp Aquatics Program Director. This is to insure the safety of all Scouts involved in the merit badge class. Participating in aquatics merit badges exposes the Scout to additional risks not normally involved in recreational swimming and boating.

## Administration of the Swim Test

All persons participating in BSA Aquatics are classified according to swimming ability. The classification tests and test procedures have been developed and structured to demonstrate a skill level consistent with the circumstances.

The BSA Aquatics swim test classifies Scouts and Scouters into three swimming ability groups. The three swimmer ability groups are swimmer, beginner and learner.

- The swimmer test demonstrates the minimum level of swimming ability required for safe deep-water swimming.
- The beginner test demonstrates that the Scout is ready to learn deep-water skills and has the minimum ability required for safe instructional and recreational activity in a confined swimming area in which shallow waters, sides, or other support are less than 25 feet from any point on the water.
- All Scouts and Scouters who do not complete the beginner test or who choose to not participate in any test are classified as learners. All learners should be encouraged to take swim lessons to improve their swimming ability and become comfortable participating in water activities.

# The BSA Swimmer and Beginner Test

## • Swimmer Test

Jump feet first into water over the head in depth, level off and begin swimming. Swim 75 yards in a strong manner using one or more of the following strokes: sidestroke, breaststroke, trudgen or crawl; then swim 25 yards using an easy, resting backstroke. The 100 yards must be completed in one swim without stops and must include at least one sharp turn. After completing the swim, rest by floating.

## • Beginner Test

Jump feet first into water over the head in depth, level off, swim 25 feet on the surface, stop, turn sharply, resume swimming as before, and return to starting place.

## Who can administer the test outside of camp?

The swim classification test is done at a unit level should be conducted by one of the following council-approved resource people: Aquatics Instructor, BSA; Cub Scout Aquatics Supervisor; BSA Lifeguard; certified lifeguard; swimming instructor; or swim coach. When the unit goes to a summer camp, each individual may be issued a buddy tag under the direction of the aquatics program director for use at the camp. **The swim Check Administrator MUST be approved before the test is administered.**

## Reasons for not Passing the Test

A successful Scouting activity is accomplished only by carefully planning the activity. The BSA swim test is one tool in planning a successful and safe aquatics activity. The BSA has identified several reasons for a Scout or Scouter to not successfully complete the BSA swim test.

The following are reasons a Scout or Scouter **WILL NOT** pass the BSA swim test:

- Underwater swimming
- Dog paddling
- Resting in the middle of the test
- Treading water and not maintaining a forward motion
- Not floating at the end of the test
- Swimming too fast and appearing to be too tired at the end of the test

## Safe Swim Defense and Safety Afloat

All eight points of the Safe Swim Defense and all nine points of Safety Afloat must be followed at all times when including aquatics activities in the unit's activities.

The eight points of Safe Swim Defense include: Qualified Supervision; Physical Fitness; Safe Area; Lifeguards on Duty; Lookout; Ability Groups; Buddy System; Discipline







**Knox Trail Council**  
Boy Scouts of America  
490 Union Avenue  
Framingham, MA 01702  
508-872-6551  
508-872-9092 fax  
[www.ktc-bsa.org](http://www.ktc-bsa.org)  
[www.campresolute.org](http://www.campresolute.org)